



RETRIEVING TOOL FOR 7" WR SET BRIDGE PLUG

Manual No:
DL-735-7000-941

Revision: **B**

Revision Date:
04/08/2019

Authored by: J.Anderson

Approved by: K.Riggs

A) DESCRIPTION

The Retrieving Tool for WR Set Bridge Plug is used to set and retrieve the WR Set Bridge Plug.

NOTE₁: Refer to applicable WR Bridge Plug technical manual for technical information specific to the WR Bridge Plug including operating procedures and plug disassembly and assembly.

B) RELATED TOOLS (sold separately)

B-1) 7" WR Set Bridge Plug (PN varies)—refer to applicable technical manual.

C) SPECIFICATION GUIDE

CASING SIZE (INCHES)	TOOL OD (INCHES)	THREAD CONNECTION (BOX UP)	PART NUMBER
7	5.82	3-1/2 EUE	73570RT

D) PRE-INSTALLATION INSPECTION PROCEDURES

CAUTION: D&L ships tool connections made-up **HAND TIGHT**—labeled with hand-tight tape on the tool (Fig. 1)—unless stated otherwise. Tighten/torque all connections properly before operating tool.



Fig. 1

GENERAL THREAD CONNECTION TORQUE RECOMMENDATIONS			
STUB ACME / ACME THREADS	INTERNAL TAPERED TUBING THREADS		PREMIUM THREADS
	UP TO 2-3/8"	GREATER THAN 2-3/8"	
600 – 800 FT-LBS	600 – 800 FT-LBS	800 – 1,200 FT-LBS	Consult thread manufacturer's recommendations.

GENERAL SCREW TORQUE RECOMMENDATIONS									
SCREW SIZE (INCHES)	#6	#8	#10	1/4	5/16	3/8	7/16	1/2	5/8 and larger
TORQUE RANGE (INCH-POUNDS)	5 – 8	10 – 15	18 – 25	25 – 40	50 – 80	90 – 135	160 – 210	250 – 330	450 - 650

Before first use, D&L recommends disassembly and inspection of the tool unless stated otherwise. Ensure parts have not been damaged during shipping. Replace damaged parts with D&L replacement parts. Contact D&L sales for replacement part information.

Re-assemble the tool after inspection. Install parts in the correct order and orientation. Properly tighten connections.

Before re-using the tool, D&L recommends disassembly and inspection of the tool. Clean parts and ensure parts are in good working condition. Replace worn or damaged parts with D&L replacement parts.

D & L OIL TOOLS
P.O. BOX 52220 TULSA, OK 74152
PHONE: (800) 441-3504 www.dloiltools.com



RETRIEVING TOOL FOR 7" WR SET BRIDGE PLUG

Manual No:
DL-735-7000-941

Revision: **B**

Revision Date:
04/08/2019

Authored by: J.Anderson

Approved by: K.Riggs

E) OPERATING PROCEDURES

Run retrieving tool downhole to depth of WR Bridge Plug, mill out as necessary to clear debris. Set down onto WR Bridge Plug to engage latch with approximately 1,200 – 4,800 lbs (1,200 lbs/screw). This shifts the equalizing sleeve downwards opening the equalizing ports, and latches the retrieving collet into the latch of WR Bridge Plug.

NOTE₁: Refer to WR Bridge Plug technical manual for detailed retrieval instructions.

F) STORAGE RECOMMENDATIONS

Store the tool, if possible, in an enclosed, temperature and humidity controlled environment. Avoid excessively high temperatures over long periods of time. Keep tool dry and protected from condensation. Do not store in contact with or near volatile or corrosive chemicals.

G) RECOMMENDED HAND TOOLS

- VISE
- GLOVES
- ALLEN WRENCHES
- TAPE MEASURE
- O-RING PICK
- BAR
 - 1/2-INCH
 - 3/4-INCH
- PAINT BRUSH, 2-INCH
- PIPE WRENCH, 3-FT (2 EA)
- “CHEATER” PIPE, 4-FT LONG
- ADJUSTABLE WRENCH, 12-INCH
- CORDLESS DRILL, 18V
- SNAP RING SPREADER PLIERS
- ALIGNING PUNCH
- SCREWDRIVER SET, FLAT-TIPPED
- SOCKET SETS
 - 3/8-INCH DRIVE
 - 1/2-INCH DRIVE
- HAMMERS
 - SLEDGE
 - BALL PEEN
 - DEAD BLOW

H) DISASSEMBLY

H-1) Clamp top sub (1) in vise.

H-1.1) Unscrew and remove set screws (5) from millout shoe (4).

H-1.2) Unscrew and remove millout shoe (4) from shifting sleeve (3).

H-1.3) Unscrew and remove set screws (5) from shifting sleeve (3).

H-1.4) Unscrew and remove shifting sleeve (3) from top sub (1).

H-1.5) Remove latch (2) from top sub (1).

H-2) Unclamp and remove top sub (1) from vise.

I) ASSEMBLY

NOTE₂: Clean and inspect all parts. Replace all worn and damaged parts. Install parts in proper order, and orientation and tighten/torque all connections properly.

I-1) Clamp top sub (1) in vise.

I-1.1) Install latch (2) onto top sub (1).

I-1.2) Screw shifting sleeve (3) onto top sub (1).

I-1.3) Screw set screws (5) into shifting sleeve (3).

I-1.4) Screw millout shoe (4) onto shifting sleeve (3).

I-1.5) Screw set screws (5) into millout shoe (4).

I-2) Unclamp top sub (1) and remove assembled tool from vise.



RETRIEVING TOOL FOR 7" WR SET BRIDGE PLUG

Manual No:
DL-735-7000-941

Revision: **B**

Revision Date:
04/08/2019

Authored by: J.Anderson

Approved by: K.Riggs

J) PARTS LIST

ITEM	QTY	DESCRIPTION	MATERIAL	PART NUMBER
1	1	TOP SUB	DLMS110	73570906
2	1	LATCH	DLMS110	73570905
3	1	SHIFTING SLEEVE	DLMS110	73570710
4	1	MILLOUT SHOE	DLMS110	73570711
5	6	SET SCREW 1/4-20 UNC X 1/4	STEEL	SSS025C025

ASSEMBLED WEIGHT	51 LBS
------------------	--------

K) TECHNICAL ILLUSTRATION

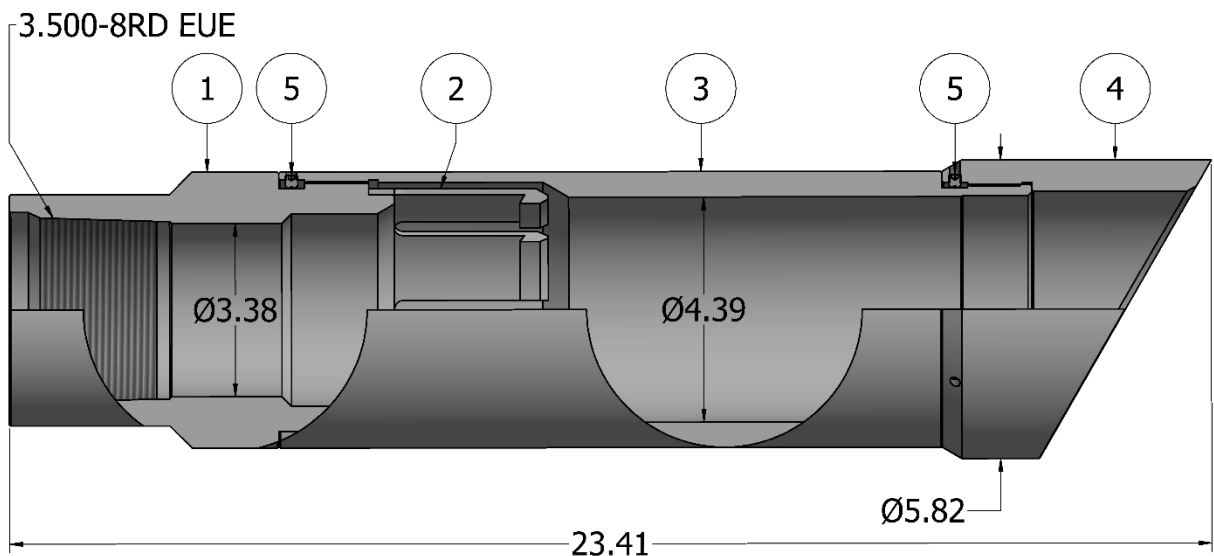

NOTE: 575 LBS AXIAL FORCE IS REQUIRED TO DEFLECT COLLET FINGERS



RETRIEVING TOOL FOR 7" WR SET BRIDGE PLUG

Manual No:
DL-735-7000-941

Revision: **B**

Revision Date:
04/08/2019

Authored by: *J.Anderson*

Approved by: *K.Riggs*

L) REVISION HISTORY

DATE	REVISION	DESCRIPTION OF CHANGES	REVISED BY	APPROVED BY
04/08/2019	B	Added Pre-Installation Inspection Procedures; Revised Tech. Illustration, assembled weight was 52 lbs	J.Anderson	K.Riggs
09/14/2015	A	Created new manual	-	-