



WIRELINE ADAPTER KIT

FOR 3-1/2” WR BRIDGE PLUG, #10 HYDRAULIC SETTING TOOL

Manual No:
DL-735-3500-1400

Revision: **A**

Revision Date:
10/14/2020

Authored by: J.Anderson

Approved by: E.Visaez

A) DESCRIPTION

The Wireline Adapter Kit (WLAK) for the WR Bridge Plug is used to set the WR Bridge Plug on electric wireline or with a hydraulic setting assembly on tubing. The WLAK for WR Bridge Plug is designed to be used on a Baker E-4 wireline powder charge or hydraulic setting assembly (or any setting assembly with the same configuration).

The WLAK automatically disconnects from the WR Bridge Plug during packer setting to be easily retrieved and prepared to run again.

NOTE1: Refer to applicable Wireline Set Bridge Plug technical manual for plug specific technical information including operating procedures and plug disassembly and assembly.

NOTE2: Pressure setting assembly sold separately.

B) RELATED TOOLS (sold separately)

B-1) 3-1/2” WR Bridge Plugs (PN varies)—refer to applicable technical manual.

C) SPECIFICATION GUIDE

TOOL OD (INCHES)	PRESSURE SETTING TOOL	PART NUMBER
2.75	#10 BAKER E-4	73535-10

D) OPERATING PROCEDURES

Assemble WLAK to WR Bridge Plug and pressure setting assembly. Run assembly to the desired depth. Follow pressure setting assembly manufacturer’s procedures for setting equipment. The WLAK disconnects from the bridge plug as part of the setting procedure. After setting bridge plug, retrieve setting assembly and disassemble.

E) STORAGE RECOMMENDATIONS

Store the tool, if possible, in an enclosed, temperature and humidity controlled environment. Avoid excessively high temperatures over long periods of time. Keep tool dry and protected from condensation. Do not store in contact with or near volatile or corrosive chemicals.

F) RECOMMENDED HAND TOOLS

- VISE
- GLOVES
- ALLEN WRENCHES
- TAPE MEASURE
- O-RING PICK
- BAR
 - 1/2-INCH
 - 3/4-INCH
- PAINT BRUSH, 2-INCH
- PIPE WRENCH, 3-FT (2 EA)
- “CHEATER” PIPE, 4-FT LONG
- ADJUSTABLE WRENCH, 12-INCH
- CORDLESS DRILL, 18V
- SNAP RING SPREADER PLIERS
- ALIGNING PUNCH
- SCREWDRIVER SET, FLAT-TIPPED
- SOCKET SETS
 - 3/8-INCH DRIVE
 - 1/2-INCH DRIVE
- HAMMERS
 - SLEDGE
 - BALL PEEN
 - DEAD BLOW

D & L OIL TOOLS
P.O. BOX 52220 TULSA, OK 74152
PHONE: (800) 441-3504 www.dloiltools.com



WIRELINE ADAPTER KIT
FOR 3-1/2" WR BRIDGE PLUG,
#10 HYDRAULIC SETTING TOOL

Manual No: DL-735-3500-1400
Revision: A
Revision Date: 10/14/2020

Authored by: J.Anderson

Approved by: E.Visaez

G) ASSEMBLY ONTO PRESSURE SETTING ASSEMBLY AND BRIDGE PLUG

NOTE3: Clean and inspect all parts. Replace all worn and damaged parts. Install parts in proper order, and orientation and tighten/torque all connections properly.

NOTE4: Pressure setting assembly is not part of WLAK and is not shown.

G-1) Screw setting sleeve (1) onto pressure setting assembly.

G-2) Screw shear stud (3) onto WR Bridge Plug.

G-3) Screw shear stud adapter (2) onto shear stud (3).

G-4) Screw shear stud adapter (2) into pressure setting assembly. Tighten setting sleeve (1) contacts upper gage ring of WR Bridge Plug.

H) DISASSEMBLY

H-1) Unscrew and remove setting sleeve (1) from pressure setting assembly.

H-2) Unscrew and remove shear stud adapter (2) from pressure setting assembly.

I) PARTS LIST

ITEM	QTY	DESCRIPTION	MATERIAL	PART NUMBER
1	1	SETTING SLEEVE	DLMS60	73035470-10
2	1	SHEAR STUD ADAPTER	DLMS110	73035902-10
3	1	SHEAR STUD (14,000#)	DLMS110	73035901
ASSEMBLED WEIGHT				28 LBS



WIRELINE ADAPTER KIT

FOR 3-1/2" WR BRIDGE PLUG, #10 HYDRAULIC SETTING TOOL

Manual No:
DL-735-3500-1400

Revision: **A**

Revision Date:
10/14/2020

Authored by: *J.Anderson*

Approved by: *E.Visaez*

J) TECHNICAL ILLUSTRATION

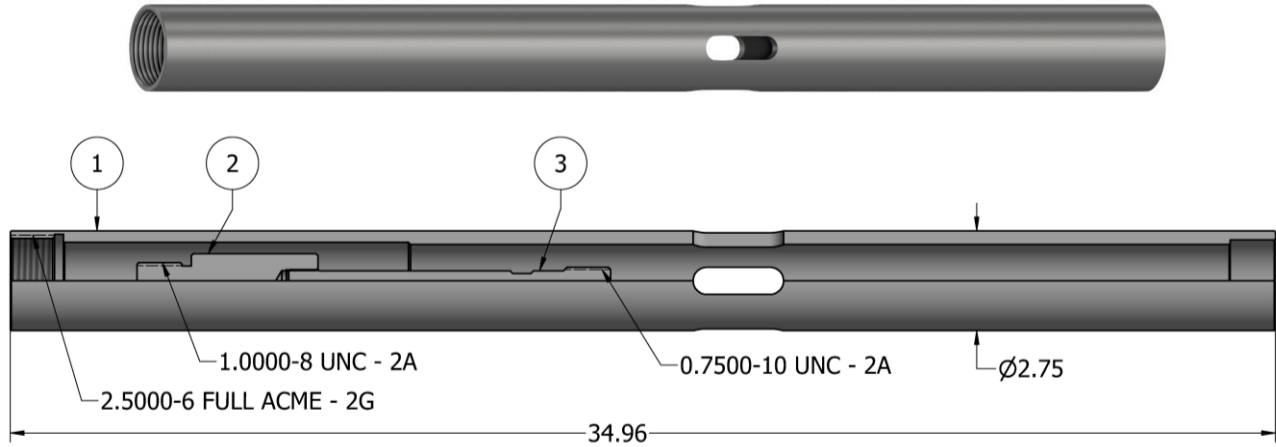

K) REVISION HISTORY

DATE	REVISION	DESCRIPTION OF CHANGES	REVISED BY	APPROVED BY
10/14/2020	A	Created new manual	-	-