



# WIRELINE ADAPTER KIT

## FOR 2-7/8” WR BRIDGE PLUG, #05 HYDRAULIC SETTING TOOL

Manual No:  
**DL-735-2875-1382**

Revision: **A**

Revision Date:  
**08/24/2020**

Authored by: J.Anderson

Approved by: E.Visaez

### A) DESCRIPTION

The Wireline Adapter Kit (WLAK) for the WR Bridge Plug is used to set the WR Bridge Plug on electric wireline or with a hydraulic setting assembly on tubing. The WLAK for WR Bridge Plug is designed to be used on a Baker E-4 wireline powder charge or hydraulic setting assembly (or any setting assembly with the same configuration).

The WLAK automatically disconnects from the WR Bridge Plug during packer setting to be easily retrieved and prepared to run again.

**NOTE1:** Refer to applicable Wireline Set Bridge Plug technical manual for plug specific technical information including operating procedures and plug disassembly and assembly.

**NOTE2:** Pressure setting assembly sold separately.

### B) RELATED TOOLS (sold separately)

B-1) 2-7/8” WR Bridge Plugs (PN varies)—refer to applicable technical manual.

### C) SPECIFICATION GUIDE

TOOL OD (INCHES)	PRESSURE SETTING TOOL	PART NUMBER
2.25	#05 BAKER E-4	73525-05

### D) OPERATING PROCEDURES

Assemble WLAK to WR Bridge Plug and pressure setting assembly. Run assembly to the desired depth. Follow pressure setting assembly manufacturer’s procedures for setting equipment. The WLAK disconnects from the bridge plug as part of the setting procedure. After setting bridge plug, retrieve setting assembly and disassemble.

### E) STORAGE RECOMMENDATIONS

Store the tool, if possible, in an enclosed, temperature and humidity controlled environment. Avoid excessively high temperatures over long periods of time. Keep tool dry and protected from condensation. Do not store in contact with or near volatile or corrosive chemicals.

### F) RECOMMENDED HAND TOOLS

- VISE
- GLOVES
- ALLEN WRENCHES
- TAPE MEASURE
- O-RING PICK
- BAR
  - 1/2-INCH
  - 3/4-INCH
- PAINT BRUSH, 2-INCH
- PIPE WRENCH, 3-FT (2 EA)
- “CHEATER” PIPE, 4-FT LONG
- ADJUSTABLE WRENCH, 12-INCH
- CORDLESS DRILL, 18V
- SNAP RING SPREADER PLIERS
- ALIGNING PUNCH
- SCREWDRIVER SET, FLAT-TIPPED
- SOCKET SETS
  - 3/8-INCH DRIVE
  - 1/2-INCH DRIVE
- HAMMERS
  - SLEDGE
  - BALL PEEN
  - DEAD BLOW

D & L OIL TOOLS  
P.O. BOX 52220 TULSA, OK 74152  
PHONE: (800) 441-3504 [www.dloiltools.com](http://www.dloiltools.com)



# WIRELINE ADAPTER KIT

FOR 2-7/8" WR BRIDGE PLUG,  
#05 HYDRAULIC SETTING TOOL

Manual No:  
**DL-735-2875-1382**

Revision: **A**

Revision Date:  
**08/24/2020**

Authored by: J.Anderson

Approved by: E.Visaez

## G) ASSEMBLY ONTO PRESSURE SETTING ASSEMBLY AND BRIDGE PLUG

**NOTE<sub>3</sub>:** Clean and inspect all parts. Replace all worn and damaged parts. Install parts in proper order, and orientation and tighten/torque all connections properly.

G-1) Slide setting sleeve (1) over lower end of pressure setting assembly.

**NOTE<sub>4</sub>:** Pressure setting assembly is not part of WLAK and is not shown.

G-2) With setting sleeve (1) up out-of-the-way, screw outer adapter (2) into pressure setting assembly.

G-3) Screw shear stud (7, on WR Bridge Plug) onto pressure setting assembly.

G-4) Slide setting sleeve (1) down over outer adapter (2). Screw setting sleeve (1) onto outer adapter (2) until lower end of setting sleeve (1) contacts WR Bridge Plug.

G-5) Screw set screws (3) into setting sleeve (1).

## H) DISASSEMBLY

H-1) Unscrew and remove set screws (3) from setting sleeve (1).

H-2) Unscrew setting sleeve (1) from outer adapter (2).

H-3) Unscrew and remove shear stud from pressure setting assembly.

H-4) Unscrew and remove outer adapter (2) from pressure setting assembly.

## I) PARTS LIST

ITEM	QTY	DESCRIPTION	MATERIAL	PART NUMBER
1	1	SETTING SLEEVE	DLMS110	73525470
2	1	OUTER ADAPTER	DLMS110	97105102
3	2	SOCKET SET SCREW 1/4-20 UNC X 1/4	STEEL	SSS025C025
4	1	SHEAR STUD (7,000#)	DLMS110	73525901

ASSEMBLED WEIGHT	8 LBS
------------------	-------



# WIRELINE ADAPTER KIT

FOR 2-7/8" WR BRIDGE PLUG,  
#05 HYDRAULIC SETTING TOOL

Manual No:  
**DL-735-2875-1382**

Revision: **A**

Revision Date:  
**08/24/2020**

Authored by: J.Anderson

Approved by: E.Visaez

## J) TECHNICAL ILLUSTRATION

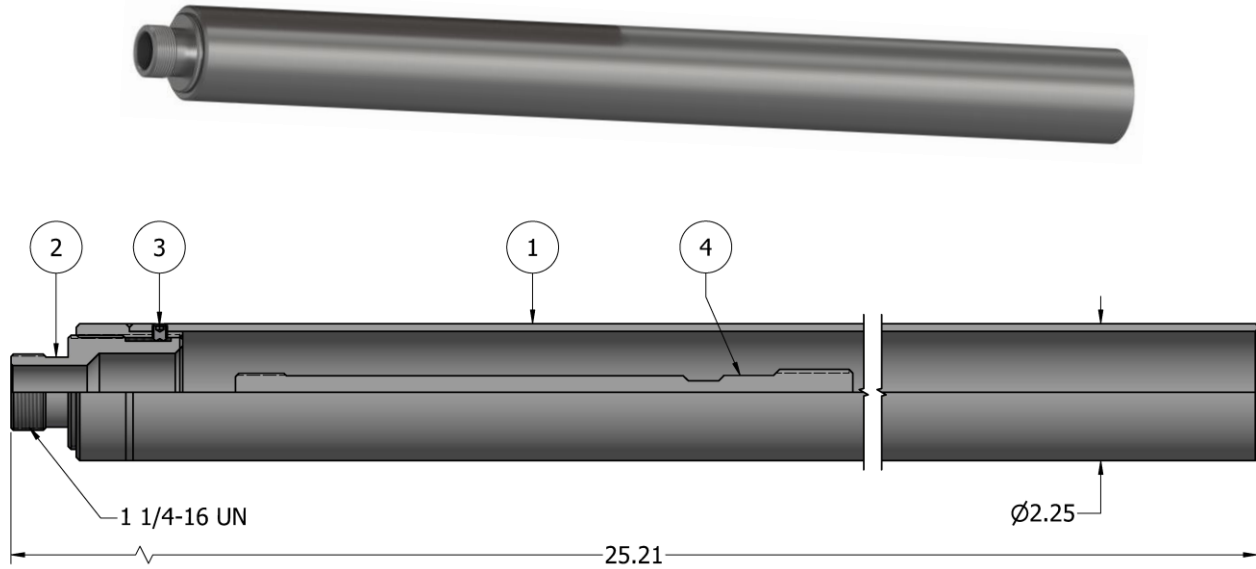

## K) REVISION HISTORY

DATE	REVISION	DESCRIPTION OF CHANGES	REVISED BY	APPROVED BY
08/24/2020	A	Created new manual	-	-