



HD RETRIEVABLE PACKER RIGHT-HAND AUTO 20" X 6-5/8" w/ 4-1/2 IF TOOL JOINT

Manual No:
DL-613-20000-773

Revision: **F**

Revision Date:
11/07/2023

Authored by: *D.Barlow*

Approved by: *K.Riggs*

A) DESCRIPTION

The HD Retrievable Packer is a heavy duty service packer ideally suited for all types of squeeze cementing, formation fracturing, high pressure acidizing, etc. It is a large opening compression set packer with hydraulic button-type hold down. This packer withstands high pressure from above or below and uses a 3-element packing system, J-slot, and a drag block mechanism for easy setting. This packer has a built-in unloader which circulates across the hold down buttons to improve retrievability and run in performance.

B) SPECIFICATION GUIDE

CASING			TOOL		THREAD CONNECTIONS BOX UP / PIN DOWN	PART NUMBER
SIZE (INCHES)	WEIGHT (LBS/FT)	RECOMMENDED HOLE SIZE (INCHES)	GAGE OD (INCHES)	NOMINAL ID (INCHES)		
20	106.5 – 133.0	18.730 – 19.000	18.500	3.75	4-1/2 IF TOOL JOINT	61320XRS-XBEE 61320XRSH-XBEE ¹ 61320XRSV-XBEE ²
	129.0 – 169.0	18.376 – 18.750	18.000	3.75	4-1/2 IF TOOL JOINT	61320RS-XBEE 61320RSH-XBEE ¹ 61320RSV-XBEE ²

Elastomer Trim Options: ¹HSN, ²Viton

NOTE₁: Tools listed are right-hand auto set / straight pick-up.

DIFFERENTIAL PRESSURE (MAX)	TENSILE LOAD THRU UNSET TOOL (MAX)	HANGING WEIGHT ON SET TOOL (MAX)*	TORQUE THRU TOOL (MAX)
3,000 PSI	575,000 LBS	460,000 LBS*	2,000 FT-LBS

*Casing must be cemented for this load rating.

CAUTION₁: Before running the tool, check the pressure affected areas chart, and consider other effects to be certain the unloader will remain closed during operation.

CAUTION₂: If the HD Packer is run with a retrievable bridge plug, make sure the bridge plug J-slot is compatible with the J-slot on the packer. Whichever direction you set the plug, the packer should set in the opposite direction.

C) PRE-INSTALLATION INSPECTION PROCEDURES

CAUTION₃: D&L ships tool connections made-up **Hand-Tight**—labeled with hand-tight tape on the tool (Fig.1)—unless stated otherwise. Tighten/torque all connections properly before operating tool.



Fig. 1

GENERAL THREAD CONNECTION TORQUE RECOMMENDATIONS			
STUB ACME / ACME THREADS	INTERNAL TAPERED TUBING THREADS		PREMIUM THREADS
	UP TO 2-3/8"	GREATER THAN 2-3/8"	
600 – 800 FT-LBS	600 – 800 FT-LBS	800 – 1,200 FT-LBS	Consult thread manufacturer's recommendations.

D & L OIL TOOLS
P.O. BOX 52220 TULSA, OK 74152
PHONE: (800) 441-3504 www.dloiltools.com



HD RETRIEVABLE PACKER

RIGHT-HAND AUTO

20" X 6-5/8" w/ 4-1/2 IF TOOL JOINT

Manual No:
DL-613-20000-773

Revision: **F**

Revision Date:
11/07/2023

Authored by: *D.Barlow*

Approved by: *K.Riggs*

C) PRE-INSTALLATION INSPECTION PROCEDURES (cont'd)

GENERAL SCREW TORQUE RECOMMENDATIONS									
SCREW SIZE (INCHES)	#6	#8	#10	1/4	5/16	3/8	7/16	1/2	5/8 and larger
TORQUE RANGE (INCH-POUNDS)	5 – 8	10 – 15	18 – 25	25 – 40	50 – 80	90 – 135	160 – 210	250 – 330	450 - 650

Before first use, D&L recommends disassembly and inspection of the tool unless stated otherwise. Ensure parts have not been damaged during shipping. Replace damaged parts with D&L replacement parts. Contact D&L sales for replacement part information.

Re-assemble the tool after inspection. Install parts in the correct order and orientation. Properly tighten connections.

Before re-using the tool, D&L recommends disassembly and inspection of the tool. Clean parts and ensure parts are in good working condition. Replace worn or damaged parts with D&L replacement parts.

When redressing the tool, D&L recommends replacement of all seals, elements, o-rings, shear screws, etc. Contact D&L sales for redress kit and/or other replacement part information.

D) SETTING PROCEDURES

CAUTION4: Do not run the tool without properly tightening connections. Running the tool with loose connections may damage the tool and cause malfunction.

Run to setting depth. The unloader remains open while running in. Pick up the tubing and rotate 1/4 turn at the packer. Slack off weight and set down on the packer to set the slips, close the unloader and compress the packing elements. A minimum weight of 40,000 lbs. at the packer is required to pack off the elements.

CAUTION5: Run the tool slowly, as with any hold down type packer, to help prevent dulling of the hydraulic buttons.

E) RELEASING PROCEDURES

Pick up on the work string to open the unloader, allowing time for the tubing and casing pressure to equalize. Continued upward movement of the work string unsets the slips, relaxes the packing elements and re-jays the packer. The tool may now be moved and reset, or pulled from the well.

F) STORAGE RECOMMENDATIONS

When preparing the tool for storage, follow the Pre-Installation Inspection Procedures. Re-assemble the tool with connections hand-tight only and in running position if applicable. Elastomers should be in a relaxed state—free from tension, compression, and other stresses that could cause deformation.

Store the tool, if possible, in an enclosed, temperature and humidity controlled environment. Avoid excessively high temperatures over long periods of time. Shield elastomeric parts from ultraviolet light sources. Keep tool dry and protected from condensation. Do not store in contact with or near volatile or corrosive chemicals. Do not store near ozone generating equipment or operations such as welding.

G) PRESSURE AFFECTED AREA GUIDE

When set downhole, the packer mandrel is subjected to a force created by differential pressure above or below the packer that acts on the pressure affected area (i.e., the piston effect). Depending on the drill pipe size and weight and the seal area of the packer the force created by differential pressure acts upwards or downwards on the packer mandrel. An upward force, designated as a negative (-) value, acts to push the packer mandrel up hole and must be accounted for to ensure that the packer remains set. A downward force, designated as a positive value, acts to push the packer mandrel down hole and must be accounted for when releasing the packer. Other factors (e.g., tubing movement due to temperature change) must be considered separately to determine all the forces acting on the packer.



HD RETRIEVABLE PACKER RIGHT-HAND AUTO 20" X 6-5/8" w/ 4-1/2 IF TOOL JOINT

Manual No:
DL-613-20000-773

Revision: **F**

Revision Date:
11/07/2023

Authored by: D.Barlow

Approved by: K.Riggs

G) PRESSURE AFFECTED AREA GUIDE (cont'd)

PACKER SIZE (IN)	DRILL PIPE TO PACKER			PRESSURE AFFECTED AREA (IN ²)	
	SIZE (IN)	WEIGHT (LB/FT)	ID (IN)	ABOVE	BELOW
20	ABANDONED	N/A	PLUGGED	35.520 (DOWN)	-5.479 (UP)
	2.375*	4.85	1.995	31.090 (DOWN)	-2.353 (UP)
		6.65	1.815	31.090 (DOWN)	-2.891 (UP)
	2.875*	6.85	2.441	29.028 (DOWN)	-0.799 (UP)
		10.40	2.151	29.028 (DOWN)	-1.845 (UP)
	3.500	8.50	3.063	25.899 (DOWN)	1.890 (DOWN)
		13.30	2.764	25.899 (DOWN)	0.522 (DOWN)
		15.50	2.602	25.899 (DOWN)	-0.161 (UP)
	4.000	11.85	3.476	22.954 (DOWN)	4.011 (DOWN)
		14.00	3.340	22.954 (DOWN)	3.283 (DOWN)
		15.70	3.240	22.954 (DOWN)	2.766 (DOWN)
	4.500	13.75	3.958	19.616 (DOWN)	6.825 (DOWN)
		16.60	3.826	19.616 (DOWN)	6.018 (DOWN)
		20.00	3.640	19.616 (DOWN)	4.928 (DOWN)
		22.82	3.500	19.616 (DOWN)	4.142 (DOWN)
	5.000	16.25	4.408	15.885 (DOWN)	9.782 (DOWN)
		19.50	4.276	15.885 (DOWN)	8.882 (DOWN)
		25.60	4.000	15.885 (DOWN)	7.088 (DOWN)
	5.500	19.20	4.892	11.762 (DOWN)	13.317 (DOWN)
		21.90	4.778	11.762 (DOWN)	12.451 (DOWN)
		24.70	4.670	11.762 (DOWN)	11.650 (DOWN)
	5.875	23.40	5.153	8.412 (DOWN)	15.376 (DOWN)
		24.17	5.045	8.412 (DOWN)	14.511 (DOWN)
	6.625	25.20	5.965	1.049 (DOWN)	22.467 (DOWN)
		27.70	5.901	1.049 (DOWN)	21.870 (DOWN)

*Drill pipe sizes not recommended.

Example: Consider a 20" X 6-5/8" HD Packer set on 4.500" (20.00 lbs/ft) drill pipe with a differential pressure of 3,000 PSI in the annulus around the drill pipe above the packer. What is the force acting on the seal area of the mandrel?

To calculate the force (lbs) acting on the seal area of the mandrel, refer to the Pressure Affected Area Guide for a 20" X 6-5/8" HD Packer run on 4.500" (20.00 lbs/ft) drill pipe. In this example, the differential pressure from above the packer acts on the seal area of the packer mandrel across a pressure affected area of 19.616 in². Multiplying the differential pressure (3,000 PSI) by the pressure affected area (19.616 in²) results in a force of 58,848 lbs. The piston effect on the packer mandrel is a downward force of 58,848 lbs.



HD RETRIEVABLE PACKER RIGHT-HAND AUTO 20" X 6-5/8" w/ 4-1/2 IF TOOL JOINT

Manual No:
DL-613-20000-773

Revision: **F**

Revision Date:
11/07/2023

Authored by: D.Barlow

Approved by: K.Riggs

H) ELASTOMER TRIM TEMPERATURE GUIDE

NITRILE (STD)			
TEMPERATURE RANGE (F°)	DUROMETER		
	END	MIDDLE	END
40° - 125°	80	70	80
125° - 250°	90	70	90
150° - 250°	90	80	90
250° +	Contact D&L Sales		

RUBBER TYPE	TEMPERATURE RANGE (F°)
NITRILE	40° - 250°F
HSN (HNBR)	70° - 300°F
VITON	100° - 350°F

I) RECOMMENDED TOOLS

I-1) HAND TOOLS

- VISE
- GLOVES
- ALLEN WRENCHES
- TAPE MEASURE
- O-RING PICK
- BAR
 - 1/2-INCH
 - 3/4-INCH
- PAINT BRUSH, 2-INCH
- PIPE WRENCH, 3-FT (2 EA)
- "CHEATER" PIPE, 4-FT LONG
- ADJUSTABLE WRENCH, 12-INCH
- CORDLESS DRILL, 18V
- SNAP RING SPREADER PLIERS
- ALIGNING PUNCH
- SCREWDRIVER SET, FLAT-TIPPED
- SOCKET SETS
 - 3/8-INCH DRIVE
 - 1/2-INCH DRIVE
- HAMMERS
 - SLEDGE
 - BALL PEEN
 - DEAD BLOW
- JACK STAND

I-2) SPECIAL TOOLS

ITEM	QTY	DESCRIPTION	PART NUMBER
T1	1	DRAG BLOCK ASSEMBLY TOOL	AT018110
T2	1	BUTTON REMOVAL TOOL	AT-BRT000
T3	1 GAL	KOPR-KOTE® ANTI-SEIZE LUBRICANT	DL-KOPR-KOTE-1G

J) DISASSEMBLY

J-1) Clamp top sub (1) in vise.

NOTE₂: Ensure vise is capable of handling weight of tool.

NOTE₃: Support tool during disassembly and assembly with jack stands as necessary.

J-1.1) Beginning at lower end of tool, unscrew and remove set screws (43) from J-pin sub (23).

J-1.2) Unscrew and remove bottom sub (28) from J-pin sub (23).

J-1.3) Unscrew and remove set screws (44) from J-pin sub (23). Move J-body (20) as needed to access set screws (41).

J-1.4) Unscrew and remove J-pin sub (23) from inner mandrel (2).

NOTE₄: Drag block body assembly must be free to rotate.

J-1.4.1) Remove o-rings (49) from J-pin sub (23).

J-1.5) Unscrew and remove set screws (44) from drag block body support (27).

J-1.6) Unscrew J-body (20) from drag block body support (27) (**NOTE₅:** Left-hand threads).

J-1.7) Unscrew and remove rubber mandrel cap (19) from rubber mandrel (11). Move drag block body assembly as needed to access rubber mandrel cap (19).

NOTE₆: For added leverage, insert a rod through central body (10) as needed.



HD RETRIEVABLE PACKER

RIGHT-HAND AUTO

20" X 6-5/8" w/ 4-1/2 IF TOOL JOINT

Manual No:
DL-613-20000-773

Revision: **F**

Revision Date:
11/07/2023

Authored by: D.Barlow

Approved by: K.Riggs

J) DISASSEMBLY (cont'd)

J-1.8) Remove drag block body assembly and disassemble:

J-1.8.1) Compress drag blocks (22) with drag block assembly tool (T1). Unscrew and remove drag block retainer (21) from drag block body support (27).

J-1.8.2) Release drag blocks (22); remove drag blocks (22) and drag block springs (3) from drag block body (18).

J-1.8.3) Unscrew and remove set screws (44) from drag block body (18).

J-1.8.4) Unscrew and remove drag block body support (27) from drag block body (18) (**NOTE**₅: Left-hand threads).

J-1.8.5) Wedge lower slips (17) outward (if needed). Unscrew and remove cap screws (41) from drag block body (18).

J-1.8.6) Remove lower slip support sleeve (39) from drag block body (18).

J-1.8.7) Remove wedges (if needed). Remove lower slips (17) and lower slip springs (25) from drag block body (18).

J-1.9) Unscrew and remove lower cone support (36) from lower cone (16).

J-1.10) Unscrew and remove lower cone (16) from rubber retainer (15).

J-1.11) Unscrew rubber mandrel (11) from valve body (31).

J-1.12) Remove rubber mandrel assembly and disassemble:

J-1.12.1) Remove elements (13, 14), rubber spacers (12) and rubber retainer (15) from rubber mandrel sleeve (38).

J-1.12.2) Remove rubber mandrel sleeve (38) from rubber mandrel (11).

J-1.12.3) Remove o-ring (47) from rubber mandrel (11).

J-1.13) Unscrew and remove gage ring (29) from valve body (31).

J-1.14) Unscrew and remove valve body (31) from central body (10).

NOTE₆: For added leverage, insert a rod through central body (10) as needed.

J-1.14.1) Remove bonded seal (24) from valve body (31).

J-1.14.2) Remove o-rings (45) from valve body (31).

J-1.15) Unscrew and remove central body (10) from hold down body adapter (32).

J-2) Remove top sub (1) from vise and clamp lower end of inner mandrel (2) in vise.

CAUTION₆: Do **NOT** wrench or clamp on seal surface.

J-2.1) From upper end of tool, unscrew and remove set screws (44) from top sub (1).

J-2.2) Unscrew and remove top sub (1) from inner mandrel (2).

J-2.2.1) Remove o-ring (49) from top sub (1).

J-2.3) Unscrew and remove upper hold down retaining ring (7) from hold down body cap (4).

J-2.4) Unscrew lower hold down retaining ring (7) from hold down body base (6). Slide lower hold down retaining ring (7) out-of-the-way temporarily.

J-2.5) Unscrew and remove hold down body cap (4) from hold down body extension (33).

J-2.6) Remove hold down rings assembly from hold down body sleeve (34) and disassemble:

J-2.6.1) Separate hold down rings (35). Remove hold down body retaining ring (40) and locator pins (42) from hold down ring(s) (35).

J-2.6.2) Unscrew and remove flat head cap screws (26) from hold down rings (35).

J-2.6.3) Remove hold down straps (37) from hold down rings (35).

J-2.6.4) Remove hold down button springs (3) from hold down rings (35).



HD RETRIEVABLE PACKER RIGHT-HAND AUTO 20" X 6-5/8" w/ 4-1/2 IF TOOL JOINT

Manual No:
DL-613-20000-773

Revision: F

Revision Date:
11/07/2023

Authored by: D.Barlow

Approved by: K.Riggs

J) DISASSEMBLY (cont'd)

J-2.6.5) Remove hold down buttons (30) from hold down rings (35) with button removal tool (T2).

J-2.6.5.1) Remove o-rings (48) from hold down buttons (30).

J-2.6.6) Remove o-rings (54) from hold down rings (35).

J-2.7) Unscrew and remove hold down body base (6) from hold down body adapter (32).

J-2.8) Remove hold down body assembly and disassemble:

J-2.8.1) Unscrew and remove hold down body extension (33) from hold down body sleeve (34).

J-2.8.1.1) Remove o-rings (50, 55) from hold down body extension (33).

J-2.8.2) Unscrew and separate hold down body sleeve (34) from hold down body adapter (32).

J-2.8.2.1) Remove o-rings (52) from hold down body sleeve (34).

J-2.8.2.2) Remove o-ring (53) from hold down body adapter (32).

J-2.9) Remove lower hold down retaining ring (7) from inner mandrel (2).

J-2.10) Remove compensating piston (9) from compensating mandrel (8).

J-2.10.1) Remove o-rings (51, 53) from compensating piston (9).

J-2.11) Unscrew and remove compensating mandrel (8) from seal receptacle (5).

J-3) Unclamp and remove inner mandrel (2) from vise.

J-4) Remove seal receptacle (5) from inner mandrel (2).

J-4.1) Remove o-ring (46) from seal receptacle (5).

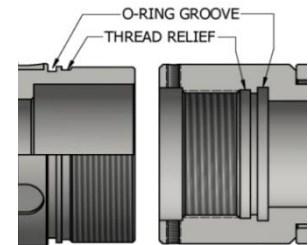

Fig. 2

K) ASSEMBLY

NOTE₇: Clean and inspect all parts. Replace all worn and damaged parts. Install parts in proper order, and orientation and tighten/torque all connections properly.

CAUTION₇: To ensure tool operates properly, install o-rings in o-ring grooves **NOT** thread reliefs (Fig. 2).

NOTE₈: Apply KOPR-KOTE anti-seize lubricant (T3) on STUB ACME and drill pipe connections when making up connections.

NOTE₂: Ensure vise is capable of handling weight of tool.

NOTE₃: Support tool during disassembly and assembly with jack stands as necessary.

K-1) Install o-ring (46) into o-ring groove in seal receptacle (5).

K-2) From lower end of inner mandrel (2), install seal receptacle (5) onto inner mandrel (2).

K-3) Clamp lower part of inner mandrel (2) in vise.

CAUTION₆: Do **NOT** wrench or clamp on seal surface.

K-3.1) From upper end of inner mandrel (2), screw compensating mandrel (8) into seal receptacle (5).

CAUTION₈: Do not rip or tear o-ring during installation.

K-3.2) Install o-rings (51, 53) into o-ring grooves in compensating piston (9).

K-3.3) Install compensating piston (9) onto compensating mandrel (8).

NOTE₉: Compensating piston **MUST** be installed in correct direction (Fig. 3).

CAUTION₈: Do not rip or tear o-ring during installation.

K-3.4) Loosely install lower hold down retaining ring (7) onto inner mandrel (2) to be screwed onto hold down body base (6) in later step.

K-3.5) Assemble hold down body assembly and install:

K-3.5.1) Install o-ring (53) into o-ring groove in hold down body adapter (32).

K-3.5.2) Install o-rings (52) into o-ring grooves in hold down body sleeve (34).

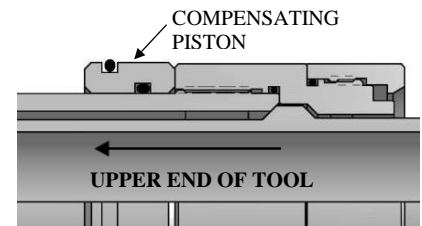

Fig. 3



HD RETRIEVABLE PACKER RIGHT-HAND AUTO 20" X 6-5/8" w/ 4-1/2 IF TOOL JOINT

Manual No:
DL-613-20000-773

Revision: F

Revision Date:
11/07/2023

Authored by: D.Barlow

Approved by: K.Riggs

K) ASSEMBLY (cont'd)

K-3.5.3) Screw hold down body sleeve (34) onto hold down body adapter (32).

CAUTION₈: Do not rip or tear o-ring during installation.

K-3.5.4) Install o-rings (50, 55) into o-ring grooves in hold down body extension (33).

K-3.5.5) Screw hold down body extension (33) into hold down body sleeve (34).

CAUTION₈: Do not rip or tear o-ring during installation.

K-3.5.6) Install hold down body assembly onto inner mandrel (2).

CAUTION₈: Do not rip or tear o-rings during installation.

K-3.6) Screw hold down body base (6) onto hold down body adapter (32).

K-3.7) Assemble hold down rings assembly and install:

K-3.7.1) Install o-rings (54) into o-ring grooves in hold down rings (35).

K-3.7.2) Install o-rings (48) into o-ring grooves in hold down buttons (30).

K-3.7.3) Install hold down buttons (30) into hold down rings (35) (Fig. 4).

CAUTION₈: Do not rip or tear o-rings during installation.

K-3.7.4) Align slot in hold down buttons (30) with slot in hold down rings (35). Set hold down button springs (3) in place on hold down buttons (30).

NOTE₁₀: Uses two (2ea) hold down button springs per hold down button (Fig. 5).

K-3.7.5) Set hold down straps (37) in place on hold down buttons (30) (Fig. 5).

K-3.7.6) Screw flat head cap screws (26) into hold down rings (35) (Fig. 5).

K-3.7.7) Install hold down button retaining ring (40) onto either of the hold down rings (35).

K-3.7.8) Insert locator pins (42) into holes in either hold down ring (35).

NOTE₁₁: Hold down rings (35) are unidirectional.

K-3.7.9) Align locator pins (42) with holes in hold down rings (35). Push hold down rings (35) together.

K-3.7.10) Install hold down rings assembly onto hold down body sleeve (34).

K-3.8) Screw hold down body cap (4) onto hold down body extension (33).

K-3.9) Screw lower hold down retaining ring (7) onto hold down body base (6).

K-3.10) Screw upper hold down retaining ring (7) onto hold down body cap (4).

K-3.11) Install o-ring (49) into o-ring groove in top sub (1).

K-3.12) Screw top sub (1) onto inner mandrel (2).

CAUTION₈: Do not rip or tear o-ring during installation.

K-3.13) Screw set screws (44) into top sub (1).

K-4) Unclamp and remove inner mandrel (2) from vise. Clamp top sub (1) in vise.

K-4.1) Screw central body (10) onto hold down body adapter (32).

CAUTION₈: Do not rip or tear o-ring during installation.

K-4.2) Install o-rings (45) into o-ring grooves in valve body (31).

K-4.3) Install bonded seal (24) in valve body (31).

CAUTION₈: Do not rip or tear o-rings during installation.

K-4.4) Screw valve body (31) into central body (10).

NOTE₆: For added leverage, insert a rod through central body (10) as needed.

K-4.5) Screw gage ring (29) onto valve body (31).

Upper end of tool

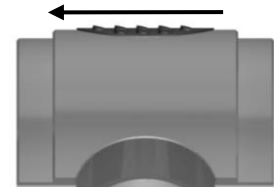

Fig. 4



Fig. 5



HD RETRIEVABLE PACKER RIGHT-HAND AUTO 20" X 6-5/8" w/ 4-1/2 IF TOOL JOINT

Manual No:
DL-613-20000-773

Revision: F

Revision Date:
11/07/2023

Authored by: D.Barlow

Approved by: K.Riggs

K) ASSEMBLY (cont'd)

K-4.6) Assemble rubber mandrel assembly and install:

K-4.6.1) Install o-ring (47) into o-ring groove in rubber mandrel (11).

K-4.6.2) Install rubber mandrel sleeve (38) onto rubber mandrel (11).

CAUTION₈: Do not rip or tear o-ring during installation.

K-4.6.3) Install rubber retainer (15), elements (13, 14), and rubber spacers (12) onto rubber mandrel sleeve (38).

K-4.7) Screw rubber mandrel (11) into valve body (31).

CAUTION₈: Do not rip or tear o-rings during installation.

K-4.8) Screw lower cone (16) into rubber retainer (15).

K-4.9) Screw lower cone support (36) into lower cone (16).

K-4.10) Assemble drag block body assembly and install:

K-4.10.1) Install lower slips (17) and lower slip springs (25) into drag block body (18). Wedge lower slips (17) outward.

NOTE₁₂: Uses two (2ea) slip springs per slip (Fig. 6).

K-4.10.2) Install lower slip support sleeve (39) into drag block body (18).

K-4.10.3) Align holes in lower slip support sleeve (39) with threaded holes in drag block body (18). Screw cap screws (41) into drag block body (18). Remove wedges.

K-4.10.4) Install drag blocks (22) and drag block springs (3) into drag block body (18). Compress drag blocks (22) with drag block assembly tool (T1).

NOTE₁₃: Uses six (6ea) drag block springs per drag block (Fig. 7).

K-4.10.5) Screw drag block body support (27) into drag block body (18) (**NOTE₅**: Left-hand threads).

K-4.10.6) Screw set screws (44) into drag block body (18).

K-4.10.7) Screw drag block retainer (21) onto drag block support (27) capturing ends of drag blocks (22). Release drag blocks (22).

K-4.10.8) Install drag block body assembly onto rubber mandrel (11).

K-4.11) Screw rubber mandrel cap (19) onto rubber mandrel (11).

NOTE₆: For added leverage, insert a rod through central body (10) as needed.

K-4.12) Screw J-body (20) into drag block body support (27) (**NOTE₅**: Left-hand threads).

K-4.13) Screw set screws (44) into drag block body support (27).

K-4.14) Install o-rings (49) into o-ring grooves in J-pin sub (23).

K-4.15) Screw J-pin sub (23) onto inner mandrel (2).

NOTE₄: Drag block body assembly must be free to rotate.

CAUTION₈: Do not rip or tear o-ring during installation.

K-4.16) Screw set screws (44) into J-pin sub (23). Move J-body (20) as needed to access threaded holes in J-pin sub (23).

K-4.17) Screw bottom sub (28) into J-pin sub (23).

CAUTION₈: Do not rip or tear o-ring during installation.

K-4.18) Screw set screws (43) into J-pin sub (23).

K-5) Unclamp top sub (1) from vise and remove assembled tool.

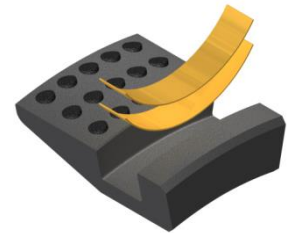

Fig. 6

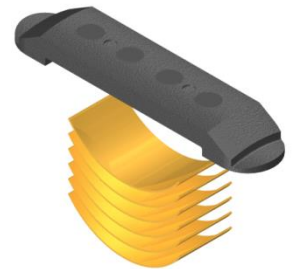

Fig. 7



HD RETRIEVABLE PACKER RIGHT-HAND AUTO 20" X 6-5/8" w/ 4-1/2 IF TOOL JOINT

Manual No:
DL-613-20000-773

Revision: **F**

Revision Date:
11/07/2023

Authored by: D.Barlow

Approved by: K.Riggs

L) PARTS LIST

ITEM	QTY	DESCRIPTION	MATERIAL	P/N 61320XRS-XBEE	P/N 61320RS-XBEE
1	1	TOP SUB	DLMS110	61316610-YBEE	
2	1	INNER MANDREL	DLMS110	61316215	
3	96	DRAG BLOCK SPRING	INCONEL	9101900	
	24	HOLD DOWN BUTTON SPRING			
4	1	HOLD DOWN BODY CAP	DLMS110	61318370	
5	1	SEAL RECEPTACLE	DLMS110	61316730	
6	1	HOLD DOWN BODY BASE	DLMS110	61318320	
7	2	HOLD DOWN RETAINING RING	DLMS110	61320X380	61320380
8	1	COMPENSATING MANDREL	DLMS110	61316240	
9	1	COMPENSATING PISTON	DLMS110	61316715	
10	1	CENTRAL BODY	DLMS110	61316385	
11	1	RUBBER MANDREL	DLMS110	60316220	
12	2	RUBBER SPACER	DLMS35	60220X840	60220840
13	1	ELEMENT	80 DURO NITRILE	60220X512	60220512
14	2	ELEMENT	90 DURO NITRILE	60220X513	60220513
15	1	RUBBER RETAINER	DLMS110	61320X850	61320850
16	1	LOWER CONE	DLMS110	61320X420	61318420
17	6	LOWER SLIP W/ CARBIDE	DLMS110	60020135C	
18	1	DRAG BLOCK BODY	DLMS110	60320X335	60320335
19	1	RUBBER MANDREL CAP	DLMS110	60316230	
20	1	J-BODY	DLMS110	61316340	
21	1	DRAG BLOCK RETAINER	DLMS110	60020X910	60020910
22	16	DRAG BLOCK W/ CARBIDE	DLMSDB4	9080900C	
23	1	J-PIN SUB	DLMS110	61316620	
24	1	BONDED SEAL	90 DURO NITRILE	60016520	
25	12	LOWER SLIP SPRING		7116901	
26	24	FLAT HEAD CAP SCREW 5/16-18 UNC X 5/8	STEEL	FHSC031C062	
27	1	DRAG BLOCK BODY SUPPORT	DLMS110	60318330	
28	1	BOTTOM SUB	DLMS110	61316630-YBEE	
29	1	GAGE RING	DLMS110	60220X830	60220830



HD RETRIEVABLE PACKER RIGHT-HAND AUTO 20" X 6-5/8" w/ 4-1/2 IF TOOL JOINT

Manual No:
DL-613-20000-773

Revision: **F**

Revision Date:
11/07/2023

Authored by: *D.Barlow*

Approved by: *K.Riggs*

L) PARTS LIST (cont'd)

ITEM	QTY	DESCRIPTION	MATERIAL	P/N 61320XRS-XBEE	P/N 61320RS-XBEE
30	12	HOLD DOWN BUTTON	DLMSSP	61316975	
31	1	VALVE BODY	DLMS110	61318350	
32	1	HOLD DOWN BODY ADAPTER	DLMS110	61316325	
33	1	HOLD DOWN BODY EXTENSION	DLMS110	61316326	
34	1	HOLD DOWN BODY SLEEVE	DLMS110	61316330	
35	2	HOLD DOWN RING	DLMS110	61320X310	61320310
36	1	LOWER CONE SUPPORT	DLMS110	61318421	
37	12	HOLD DOWN STRAP	DLMSFB4	61316360	
38	1	RUBBER MANDREL SLEEVE	DLMS110	60318225	
39	1	LOWER SLIP SUPPORT SLEEVE	DLMS110	60320X912	60318912
40	1	HOLD DOWN BUTTON RETAINING RING	DLMS110	61320X910	61320910
41	2	CAP SCREW 1/2-13 UNC X 1-1/2	STEEL	SCS050C150	
42	2	LOCATOR PIN	DLMS110	500100P	
43	4	SET SCREW 1/4-20 UNC X 1/2	STEEL	SSS025C050	
44	14	SET SCREW 3/8-16 UNC X 1/2	STEEL	SSS037C050	
45	2	171 O-RING	90 DURO NITRILE	90171	
46	1	264 O-RING	90 DURO NITRILE	90264	
47	1	267 O-RING	90 DURO NITRILE	90267	
48	12	338 O-RING	90 DURO NITRILE	90338	
49	3	362 O-RING	90 DURO NITRILE	90362	
50	1	364 O-RING	90 DURO NITRILE	90364	
51	1	367 O-RING	90 DURO NITRILE	90367	
52	2	372 O-RING	90 DURO NITRILE	90372	
53	2	374 O-RING	90 DURO NITRILE	90374	
54	4	376 O-RING	90 DURO NITRILE	90376	
55	2	440 O-RING	90 DURO NITRILE	90440	

REDRESS KIT (RDK)		61320X050	61320050
ASSEMBLED WEIGHT		2,931 LBS	2,814 LBS



**HD RETRIEVABLE PACKER
RIGHT-HAND AUTO
20" X 6-5/8" w/ 4-1/2 IF TOOL JOINT**

Manual No:
DL-613-20000-773

Revision: **F**

Revision Date:
11/07/2023

Authored by: *D.Barlow*

Approved by: *K.Riggs*

L) PARTS LIST (cont'd)

L-1) ELASTOMER TRIM OPTIONS

NOTE₁₄: For temperature range, refer to Elastomer Trim Temperature Guide.

L-1.1) HSN

ITEM	QTY	DESCRIPTION	MATERIAL	P/N 61320XRSH-XBEE	P/N 61320RSH-XBEE
13	1	ELEMENT	80 DURO HSN	60220X512H	60220512H
14	2	ELEMENT	90 DURO HSN	60220X513H	60220513H
24	1	BONDED SEAL	90 DURO HSN	60016520H	
45	2	171 O-RING	90 DURO HSN	90171H	
46	1	264 O-RING	90 DURO HSN	90264H	
47	1	267 O-RING	90 DURO HSN	90267H	
48	12	338 O-RING	90 DURO HSN	90338H	
49	3	362 O-RING	90 DURO HSN	90362H	
50	1	364 O-RING	90 DURO HSN	90364H	
51	1	367 O-RING	90 DURO HSN	90367H	
52	2	372 O-RING	90 DURO HSN	90372H	
53	2	374 O-RING	90 DURO HSN	90374H	
54	4	376 O-RING	90 DURO HSN	90376H	
55	2	440 O-RING	90 DURO HSN	90440H	

REDRESS KIT (RDK)		61320X050H	61320050H
-------------------	--	------------	-----------



HD RETRIEVABLE PACKER RIGHT-HAND AUTO 20" X 6-5/8" w/ 4-1/2 IF TOOL JOINT

Manual No:
DL-613-20000-773

Revision: **F**

Revision Date:
11/07/2023

Authored by: *D.Barlow*

Approved by: *K.Riggs*

L) PARTS LIST (cont'd)

L-1.2) VITON

ITEM	QTY	DESCRIPTION	MATERIAL	P/N 61320XRSV-XBEE	P/N 61320RSV-XBEE
13	1	ELEMENT	80 DURO VITON	60220X512V	60220512V
14	2	ELEMENT	90 DURO VITON	60220X513V	60220513V
24	1	BONDED SEAL	90 DURO VITON	60016520V	
45	2	171 O-RING	90 DURO VITON	90171V	
46	1	264 O-RING	90 DURO VITON	90264V	
47	1	267 O-RING	90 DURO VITON	90267V	
48	12	338 O-RING	90 DURO VITON	90338V	
49	3	362 O-RING	90 DURO VITON	90362V	
50	1	364 O-RING	90 DURO VITON	90364V	
51	1	367 O-RING	90 DURO VITON	90367V	
52	2	372 O-RING	90 DURO VITON	90372V	
53	2	374 O-RING	90 DURO VITON	90374V	
54	4	376 O-RING	90 DURO VITON	90376V	
55	2	440 O-RING	90 DURO VITON	90440V	

REDRESS KIT (RDK)		61320X050V	61320050V
-------------------	--	------------	-----------



HD RETRIEVABLE PACKER RIGHT-HAND AUTO 20" X 6-5/8" w/ 4-1/2 IF TOOL JOINT

Manual No:
DL-613-20000-773

Revision: F

Revision Date:
11/07/2023

Authored by: D.Barlow

Approved by: K.Riggs

M) TECHNICAL ILLUSTRATION

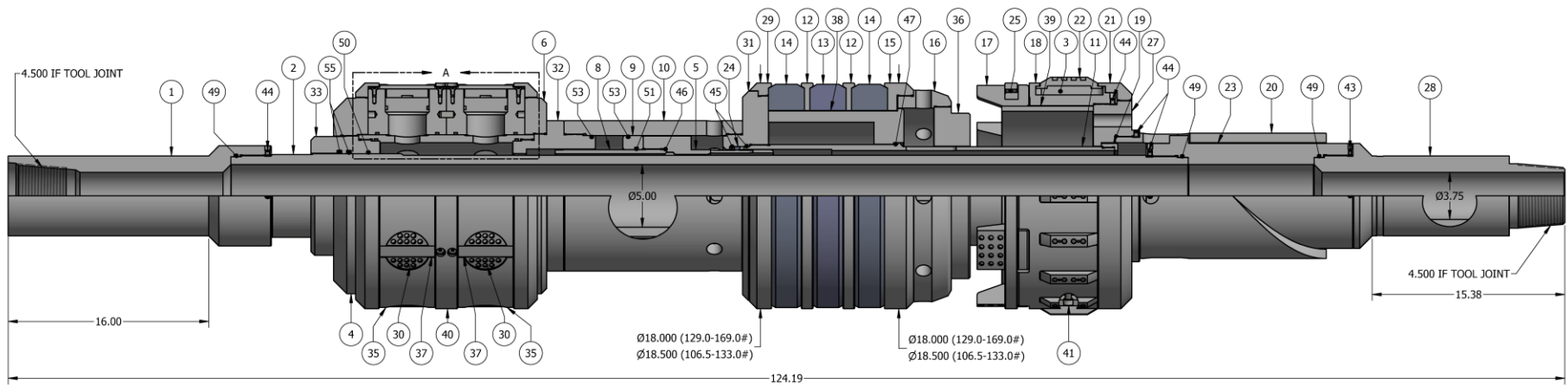

	HD RETRIEVABLE PACKER RIGHT-HAND AUTO 20" X 6-5/8" w/ 4-1/2 IF TOOL JOINT	Manual No: DL-613-20000-773
		Revision: F
		Revision Date: 11/07/2023
<i>Authored by: D.Barlow</i>		<i>Approved by: K.Riggs</i>

N) REVISION HISTORY

DATE	REVISION	DESCRIPTION OF CHANGES	REVISED BY	APPROVED BY
11/07/2023	F	Added HSN and Viton options	J.Anderson	E.Visaez
07/09/2021	E	Added 61320XRS-XBEE	J.Anderson	H.Bringham
05/16/2019	D	Revised recmm'd weight range was 133.0 – 169.0#, Elastomer Trim Temp. Guide temp rating; Added General Screw Torque Recommendations	J.Anderson	D.Hushbeck
12/04/2015	C	Revised: Title, PRE-INSTALLATION INSPECTION PROCEDURES, Elastomer Durometer Temperatures – Nitrile (90/80/90 Duro) was 250° - 300°F, Nitrile (Contact D&L Sales) was 300°F +, Rubber Type Temperature Ranges – Nitrile was 70° - 300°F, HSN was 70° - 325°F	B.Mathis	B.Oligschlaeger
11/18/2015	B	Added: Title - "RIGHT-HAND AUTO", Torque Thru Tool; Revised: STORAGE RECOMMENDATIONS was STORAGE PROCEDURES;	B.Mathis	K.Riggs
01/27/2015	A	Created new manual;	-	-