



# TYPE “E” VALVE RUNNING TOOL

## 4-1/2” X 2-3/8”, NC26 TOOL JOINT

Manual No:  
**DL-124RT-4500-1054**

Revision: **A**

Revision Date:  
**08/29/2017**

Authored by: J.Anderson

Approved by: N.Banker

### A) DESCRIPTION

The Running Tool for the Type E Valve is designed to be used with the Type E Valve to convert double grip mechanical packers (like the ASI-X Packer) into a retrievable bridge plug. This Running Tool features cutting teeth on the running shoe for breaking up compacted trash for easy removal. Running shoe OD sizes are available for centering the running tool in larger casing if needed.

### B) RELATED TOOLS (sold separately)

B-1) 4-1/2” Type “E” Valve (P/N varies)—refer to applicable technical manual.

### C) SPECIFICATION GUIDE

CASING SIZE (INCHES)	TOOL		THREAD CONNECTION BOX UP	PART NUMBER
	GAGE OD (INCHES)	NOMINAL ID (INCHES)		
4-1/2	3.75	1.78	NC26 TOOL JOINT	12445RT-XBEA

### D) PRE-INSTALLATION INSPECTION PROCEDURES

**CAUTION:** D&L ships tool connections made-up **HAND TIGHT**—labeled with hand-tight tape on the tool (Fig. 1)—unless stated otherwise. Tighten/torque all connections properly before operating tool.



Fig. 1

GENERAL THREAD CONNECTION TORQUE RECOMMENDATIONS			
STUB ACME / ACME THREADS	INTERNAL TAPERED TUBING THREADS		PREMIUM THREADS
	UP TO 2-3/8”	GREATER THAN 2-3/8”	
600 – 800 FT-LBS	600 – 800 FT-LBS	800 – 1,200 FT-LBS	Consult thread manufacturer’s recommendations.

GENERAL SCREW TORQUE RECOMMENDATIONS									
SCREW SIZE (INCHES)	#6	#8	#10	1/4	5/16	3/8	7/16	1/2	5/8 and larger
TORQUE RANGE (INCH-POUNDS)	5 – 8	10 – 15	18 – 25	25 – 40	50 – 80	90 – 135	160 – 210	250 – 330	450 - 650

Before first use, D&L recommends disassembly and inspection of the tool unless stated otherwise. Ensure parts have not been damaged during shipping. Replace damaged parts with D&L replacement parts. Contact D&L sales for replacement part information.

Re-assemble the tool after inspection. Install parts in the correct order and orientation. Properly tighten connections.

Before re-using the tool, D&L recommends disassembly and inspection of the tool. Clean parts and ensure parts are in good working condition. Replace worn or damaged parts with D&L replacement parts.

D & L OIL TOOLS  
P.O. BOX 52220 TULSA, OK 74152  
PHONE: (800) 441-3504 [www.dloiltools.com](http://www.dloiltools.com)



# TYPE “E” VALVE RUNNING TOOL

## 4-1/2” X 2-3/8”, NC26 TOOL JOINT

Manual No:  
**DL-124RT-4500-1054**

Revision: **A**

Revision Date:  
**08/29/2017**

Authored by: J.Anderson

Approved by: N.Banker

### E) OPERATING PROCEDURES

**CAUTION<sub>2</sub>:** Do not run the tool without properly tightening connections. Running the tool with loose connections may damage the tool and cause malfunction.

Use the Type “E” Running Tool to set and release the type “E” valve as required. Refer to the type “E” valve tech manual for detailed setting and releasing procedures.

### F) STORAGE RECOMMENDATIONS

When preparing the tool for storage, follow the Pre-Installation Inspection Procedures. Re-assemble the tool with connections hand-tight only and in running position if applicable.

Store the tool, if possible, in an enclosed, temperature and humidity controlled environment. Avoid excessively high temperatures over long periods of time. Keep tool dry and protected from condensation. Do not store in contact with or near volatile or corrosive chemicals. Do not store near ozone generating equipment or operations such as welding.

### G) RECOMMENDED HAND TOOLS

- VISE
- GLOVES
- ALLEN WRENCHES
- TAPE MEASURE
- O-RING PICK
- BAR
  - 1/2-INCH
  - 3/4-INCH
- PAINT BRUSH, 2-INCH
- PIPE WRENCH, 3-FT (2 EA)
- “CHEATER” PIPE, 4-FT LONG
- ADJUSTABLE WRENCH, 12-INCH
- CORDLESS DRILL, 18V
- SNAP RING SPREADER PLIERS
- ALIGNING PUNCH
- SCREWDRIVER SET, FLAT-TIPPED
- SOCKET SETS
  - 3/8-INCH DRIVE
  - 1/2-INCH DRIVE
- HAMMERS
  - SLEDGE
  - BALL PEEN
  - DEAD BLOW

### H) DISASSEMBLY

H-1) Clamp J-body (1) in vise.

H-1.1) Unscrew and remove set screws (3) from shoe (2).

H-1.2) Unscrew and remove shoe (2) from J-body (1).

H-2) Unclamp J-body (1) and remove from vise.

### I) ASSEMBLY

**NOTE<sub>1</sub>:** Clean and inspect all parts. Replace all worn and damaged parts. Install parts in proper order, and orientation and tighten/torque all connections properly.

I-1) Clamp J-body (1) in vise.

I-1.1) Screw shoe (2) onto J-body (1).

I-1.2) Screw set screws (3) into shoe (2).

I-2) Unclamp J-body (1) from vise and remove assembled tool.

### J) PARTS LIST

ITEM	QTY	DESCRIPTION	MATERIAL	P/N 12445RT-XBEA
1	1	J-BODY	DLMS110 / DLMS80	12445410-XBEA
2	1	SHOE	DLMS80	12445A409A
3	2	SET SCREW #10-32 UNF X 3/16	STEEL	SSS1032F018

ASSEMBLED WEIGHT	41 LBS
------------------	--------



# TYPE "E" VALVE RUNNING TOOL

## 4-1/2" X 2-3/8", NC26 TOOL JOINT

Manual No:  
**DL-124RT-4500-1054**

Revision: **A**

Revision Date:  
**08/29/2017**

Authored by: *J.Anderson*

Approved by: *N.Banker*

### K) TECHNICAL ILLUSTRATION

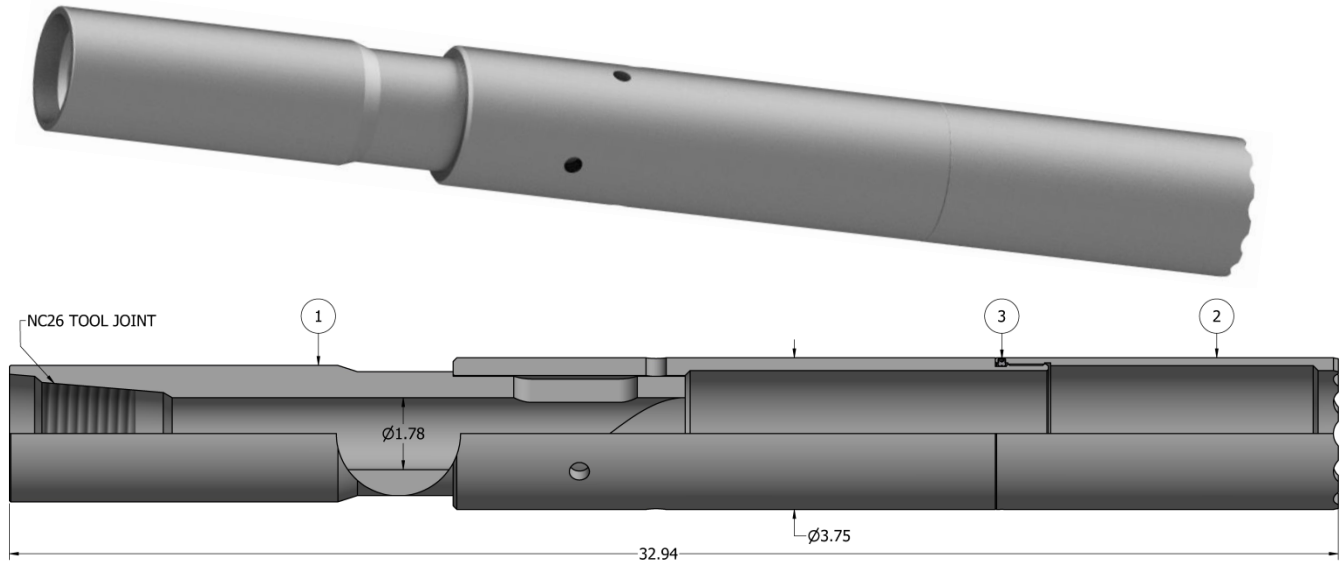

### L) REVISION HISTORY

DATE	REVISION	DESCRIPTION OF CHANGES	REVISED BY	APPROVED BY
08/29/2017	A	Created new manual	-	-