



# DL-1B TANDEM TENSION PACKER

## 5-1/2" X 2-3/8"

Manual No:  
**DL-436-5500-903**

Revision: **A**

Revision Date:  
**09/10/2015**

Authored by: J.Anderson

Approved by: K.Plunkett

### A) DESCRIPTION

The Type DL-1B Tandem Tension Packer is an economical, compact, low-pressure, tension set, isolation packer used in casing or perforations and multi-zone injection installations. This packer runs with a tension set packer below. It can be run with the J-pins in the un-jayed position or in the jayed position. In the un-jayed position, applying tension shears the shear pins and allows pack-off.

If run in the jayed position, the DL-1B Tandem Tension Packer must be used in conjunction with an ASI-X Packer. Set down weight shears the pins; left-hand rotation and applied tension will set the tool.

### B) SPECIFICATION GUIDE

CASING			TOOL			THREAD CONNECTION BOX UP / PIN DOWN	PART NUMBER
SIZE (INCHES)	WEIGHT (LBS/FT)	RECOMMENDED HOLE SIZE (INCHES)	GAGE OD (INCHES)	NOMINAL ID (INCHES)	DRIFT ID (INCHES)		
5-1/2	13.0 – 15.5	4.950 – 5.044	4.781	2.00	1.901	2-3/8 EUE	43655 43655H <sup>1</sup> 43655V <sup>2</sup>
	15.5 – 20.0	4.778 – 4.950	4.641	2.00	1.901	2-3/8 EUE	43657 43657H <sup>1</sup> 43657V <sup>2</sup>

Elastomer Trim Options: <sup>1</sup>HSN, <sup>2</sup>Viton

**NOTE<sub>1</sub>**: Tool listed is left-hand set / straight pick up release. Optional J-configurations are available.

DIFFERENTIAL PRESSURE (MAX)	TENSILE LOAD THRU TOOL (MAX)
7,000 PSI	55,000 LBS

### C) PRE-INSTALLATION INSPECTION PROCEDURES

**CAUTION<sub>1</sub>**: D&L ships tool connections made-up **HAND TIGHT**—labeled with hand-tight tape on the tool (Fig. 1)—unless stated otherwise. Tighten/torque all connections properly before operating tool.



GENERAL THREAD CONNECTION TORQUE RECOMMENDATIONS			
STUB ACME / ACME THREADS	INTERNAL TAPERED TUBING THREADS		PREMIUM THREADS
	UP TO 2-3/8"	GREATER THAN 2-3/8"	
600 – 800 FT-LBS	600 – 800 FT-LBS	800 – 1,200 FT-LBS	Consult thread manufacturer's recommendations.

Before first use, D&L recommends disassembly and inspection of the tool unless stated otherwise. Ensure parts have not been damaged during shipping. Replace damaged parts with D&L replacement parts. Contact D&L sales for replacement part information.

Re-assemble the tool after inspection. Install parts in the correct order and orientation. Properly tighten connections.

D & L OIL TOOLS  
P.O. BOX 52220 TULSA, OK 74152  
PHONE: (800) 441-3504 [www.dloiltools.com](http://www.dloiltools.com)



# DL-1B TANDEM TENSION PACKER

5-1/2" X 2-3/8"

Manual No:  
**DL-436-5500-903**

Revision: **A**

Revision Date:  
**09/10/2015**

Authored by: J.Anderson

Approved by: K.Plunkett

## C) PRE-INSTALLATION INSPECTION PROCEDURES (cont'd)

Before re-using the tool, D&L recommends disassembly and inspection of the tool. Clean parts and ensure parts are in good working condition. Replace worn or damaged parts with D&L replacement parts.

When redressing the tool, D&L recommends replacement of all elements, o-rings, shear screws, etc. Contact D&L sales for redress kit and/or other replacement part information.

## D) SETTING PROCEDURES

**CAUTION<sub>2</sub>:** Do not run the tool without properly tightening connections. Running the tool with loose connections may damage the tool and cause malfunction.

If run in the un-jayed position (straight pull), the DL-1B Tandem Tension Packer runs with a tension set packer below. Set the lower packer normally. Apply enough tension to shear the tandem tension packer pins. Continue applying tension (12,000 lbs) to pack off the packer elements.

If run in the jayed position, the DL-1B Tandem Tension Packer must be run with an ASI-X Packer below. Set the ASI-X Packer normally. Set down enough weight to shear the pins of the tandem tension packer. Apply left-hand rotation to move the J-pin out of the jayed position. Pick up on the work string with enough tension (12,000 lbs) to pack off the packer elements.

## E) RELEASING PROCEDURES

Set down weight on the work string to release the tandem tension packer and initiate the releasing sequence of the tension packer below. Follow the tension packer releasing procedures to remove the work string from down hole.

## F) STORAGE RECOMMENDATIONS

When preparing the tool for storage, follow the Pre-Installation Inspection Procedures. Re-assemble the tool with connections hand-tight only and in running position if applicable. Elements should be in a relaxed state—free from tension, compression, and other stresses that could cause deformation.

Store the tool, if possible, in an enclosed, temperature and humidity controlled environment. Avoid excessively high temperatures over long periods of time. Shield elastomeric parts from ultraviolet light sources. Keep tool dry and protected from condensation. Do not store in contact with or near volatile or corrosive chemicals. Do not store near ozone generating equipment or operations such as welding.

## G) ELASTOMER TRIM TEMPERATURE GUIDE

RUBBER TYPE	TEMPERATURE RANGE
NITRILE	70° - 300°F
HSN (HNBR)	70° - 325°F
VITON	100° - 350°F



# DL-1B TANDEM TENSION PACKER 5-1/2" X 2-3/8"

Manual No:  
**DL-436-5500-903**

Revision: **A**

Revision Date:  
**09/10/2015**

Authored by: J.Anderson

Approved by: K.Plunkett

## H) RECOMMENDED HAND TOOLS

- VISE
- GLOVES
- ALLEN WRENCHES
- TAPE MEASURE
- O-RING PICK
- BAR
  - 1/2-INCH
  - 3/4-INCH
- PAINT BRUSH, 2-INCH
- PIPE WRENCH, 3-FT (2 EA)
- "CHEATER" PIPE, 4-FT LONG
- ADJUSTABLE WRENCH, 12-INCH
- CORDLESS DRILL, 18V
- SNAP RING SPREADER PLIERS
- ALIGNING PUNCH
- SCREWDRIVER SET, FLAT-TIPPED
- SOCKET SETS
  - 3/8-INCH DRIVE
  - 1/2-INCH DRIVE
- HAMMERS
  - SLEDGE
  - BALL PEEN
  - DEAD BLOW

## I) DISASSEMBLY

- I-1) Clamp J-slot body (1) in vise.
  - I-1.1) Unscrew and remove rubber retainer (7) from J-slot body (1).
    - I-1.1.1) Remove o-ring (8) from rubber retainer (7).
  - I-1.2) Remove elements (5) from J-slot body (1).
  - I-1.3) Unscrew and remove shear screws (6) from J-pin body (3).
  - I-1.4) Unscrew and remove J-pins (4) from J-pin body (3).
  - I-1.5) Remove J-pin body (3) from J-slot body (1).
  - I-1.6) Remove mandrel (2) from J-slot body (1).
    - I-1.6.1) Remove o-rings (9) from mandrel (2).
- I-2) Unclamp and remove J-slot body (1) from vise.

## J) ASSEMBLY

**NOTE<sub>2</sub>:** Clean and inspect all parts. Replace all worn and damaged parts. Install parts in proper order, and orientation and tighten/torque all connections properly.

- J-1) Clamp J-slot body (1) in vise.
  - J-1.1) Install o-rings (9) in o-ring grooves in mandrel (2).
  - J-1.2) Install mandrel (2) into J-slot body (1). Align pocket holes in mandrel with J-slot in J-slot body.  
**CAUTION<sub>3</sub>:** Do not rip or tear o-rings during installation.
  - J-1.3) Install J-pin body (3) onto J-slot body (1). Align threaded holes for J-pins in J-pin body with J-slot in J-slot body (1) and pocket holes in mandrel (2).  
**CAUTION<sub>3</sub>:** Do not rip or tear o-ring during installation.
  - J-1.4) Screw J-pins (4) into J-pin body (3). Align threaded holes for shear screws in J-pin body with pocket holes in J-slot body (1)
  - J-1.5) Screw shear screws (6) into J-pin body (3). Tighten until shear screws (6) make contact with J-slot body (1). Back shear screws (6) out 1/4 turn.
  - J-1.6) Install elements (5) onto J-slot body (1).
  - J-1.7) Install o-ring (8) in thread relief in rubber retainer (7).
  - J-1.8) Screw rubber retainer (7) onto J-slot body (1).
- J-2) Unclamp J-slot body (1) and remove assembled tool from vise.



# DL-1B TANDEM TENSION PACKER 5-1/2" X 2-3/8"

Manual No:  
**DL-436-5500-903**

Revision: **A**

Revision Date:  
**09/10/2015**

Authored by: *J.Anderson*

Approved by: *K.Plunkett*

## K) PARTS LIST

ITEM	QTY	DESCRIPTION	MATERIAL	13.0 – 15.5# P/N 43655	15.5 – 20.0# P/N 43657
1	1	J-BODY	L-80	43655310	
2	1	MANDREL	L-80	43655210	
3	1	J-PIN BODY	1026	43655370	43657370
4	2	J-PIN	P-110	43655325	
5	1	ELEMENT	80 DURO NITRILE	43655512	43657512
6	4	SHEAR SCREW (3000#) 3/8-16 UNC X 1/2	BRASS	BSSSLT037C050	
7	1	RUBBER RETAINER	1026	43655850	43657850
8	1	234 O-RING	90 DURO NITRILE	90234	
9	2	332 O-RING	90 DURO NITRILE	90332	

REDRESS KIT (RDK)		43655050	43657050
ASSEMBLED WEIGHT		32 LBS	30 LBS

### K-1) ELASTOMER TRIM OPTIONS

**NOTE<sub>3</sub>:** For temperature range, refer to Elastomer Trim Temperature Guide.

#### K-1.1) HSN

ITEM	QTY	DESCRIPTION	MATERIAL	13.0 – 15.5# P/N 43655H	15.5 – 20.0# P/N 43657H
5	1	ELEMENT	80 DURO HSN	43655512H	43657512H
8	1	234 O-RING	90 DURO HSN	90234H	
9	2	332 O-RING	90 DURO HSN	90332H	

REDRESS KIT (RDK)		43655050H	43657050H
-------------------	--	-----------	-----------

#### K-1.2) VITON

ITEM	QTY	DESCRIPTION	MATERIAL	13.0 – 15.5# P/N 43655V	15.5 – 20.0# P/N 43657V
5	1	ELEMENT	80 DURO VITON	43655512V	43657512V
8	1	234 O-RING	90 DURO VITON	90234V	
9	2	332 O-RING	90 DURO VITON	90332V	

REDRESS KIT (RDK)		43655050V	43657050V
-------------------	--	-----------	-----------



# DL-1B TANDEM TENSION PACKER

5-1/2" X 2-3/8"

Manual No:  
**DL-436-5500-903**

Revision: **A**

Revision Date:  
**09/10/2015**

Authored by: *J.Anderson*

Approved by: *K.Plunkett*

## L) TECHNICAL ILLUSTRATION

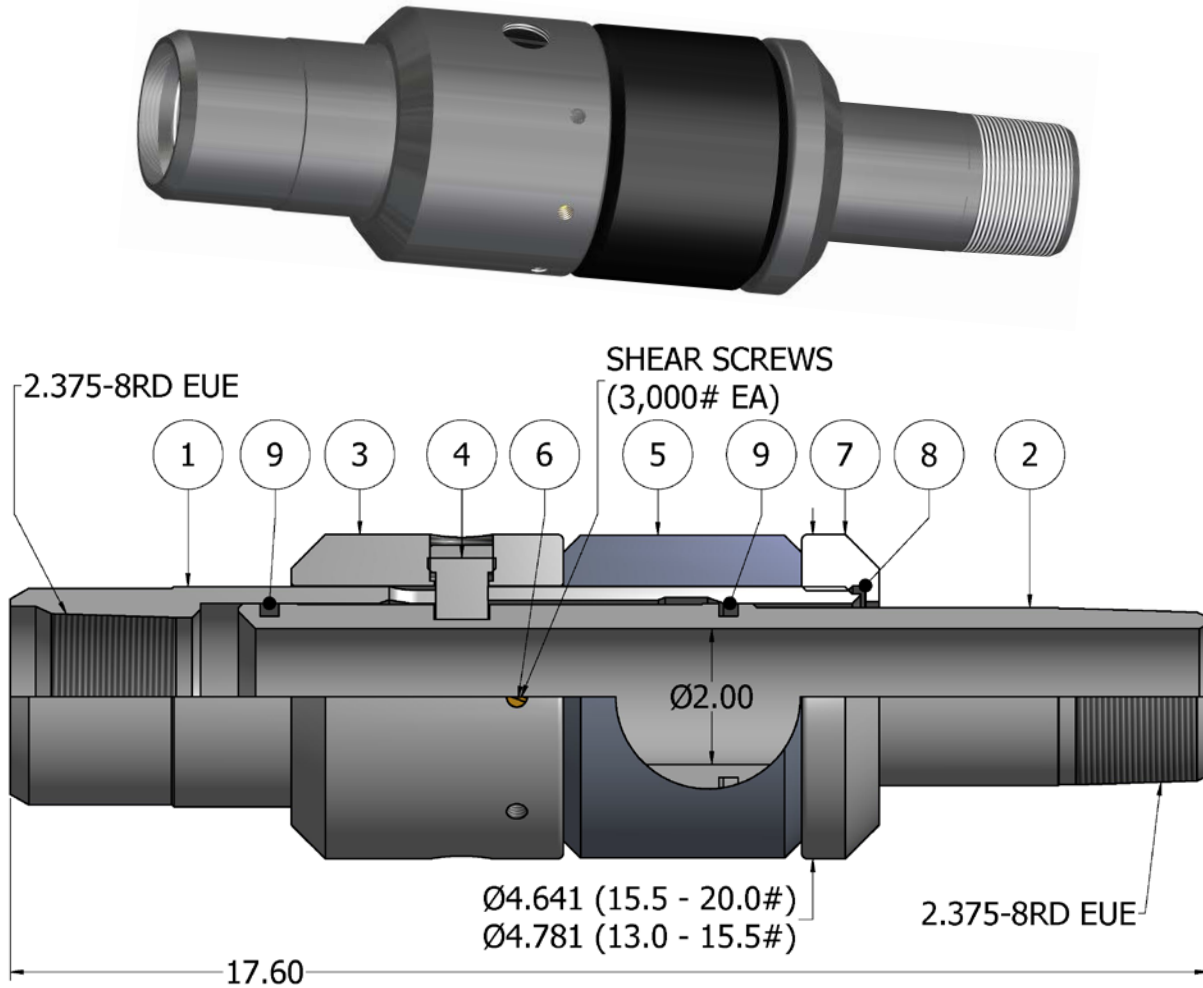

## M) REVISION HISTORY

DATE	REVISION	DESCRIPTION OF CHANGES	REVISED BY	APPROVED BY
09/10/2015	A	Created new manual	-	-