



HYDRO-X TUBING ANCHOR

5-1/2" X 2-7/8"

Manual No:
DL-324X-5500-1694

Revision: **A**

Revision Date:
08/01/2023

Authored by: J.Anderson

Approved by: E.Visaez

A) DESCRIPTION

The Hydro-X Tubing Anchor is a hydraulically activated retrievable anchor designed to hold the tubing string in tension or compression. The anchor catcher prevents movement of the tubing during pumping strokes and holds it stationary if it should part. The use of a tubing anchor increases pump efficiency, reduces rod and tubing wear, and keeps tubing and rods from falling into the well in case of a part.

The Hydro-X Tubing Anchor is operated by applying pressure to the tubing. This pressure shears screws that hold the anchor unset. A setting piston drives the slips set while locking the setting force in place. The Hydraulic Tubing Anchor utilizes heat-treated steel alloy double-acting slips for maximum holding power in tension or compression. Slips are fully enclosed for extra breakage resistance and will be retained if slips break. The anchor is retrieved by shearing screws with tension. Shear pins are added in 5,000 lb increments to achieve the desired shear value necessary to release.

The Hydro-X Anchor includes design improvements over the Hydraulic Tubing Anchor for more reliable setting and releasing.

B) RELATED TOOLS (sold separately)

B-1) Pump-Out Plug (P/N varies)—refer to technical manual *DL-597-0000-431*.

C) SPECIFICATION GUIDE

CASING			TOOL OD (INCHES)	TOOL ID (INCHES)	THREAD CONNECTION BOX UP / PIN DOWN	PART NUMBER
SIZE (INCHES)	WEIGHT (LBS/FT)	RECOMMENDED HOLE SIZE (INCHES)				
5-1/2	13.0 – 23.0	4.670 - 5.044	4.500	2.44	2-7/8 EUE	324X55 324X55H ¹ 324X55V ²

Elastomer Trim Options: ¹HSN, ²Viton

DIFFERENTIAL PRESSURE (MAX)	TENSILE LOAD THRU TOOL (MAX)	TORQUE THRU TOOL (MAX)
6,000 PSI	115,000 LBS	2,000 FT-LBS

D) PRE-INSTALLATION INSPECTION PROCEDURES

CAUTION₁: D&L ships tool connections made-up **HAND TIGHT**—labeled with hand-tight tape on the tool (Fig. 1)—unless stated otherwise. Tighten/torque all connections properly before operating tool.



Fig. 1

GENERAL THREAD CONNECTION TORQUE RECOMMENDATIONS			
STUB ACME / ACME THREADS	INTERNAL TAPERED TUBING THREADS		PREMIUM THREADS
	UP TO 2-3/8"	GREATER THAN 2-3/8"	
600 – 800 FT-LBS	600 – 800 FT-LBS	800 – 1,200 FT-LBS	Consult thread manufacturer's recommendations.

D & L OIL TOOLS
P.O. BOX 52220 TULSA, OK 74152
PHONE: (800) 441-3504 www.dloiltools.com



HYDRO-X TUBING ANCHOR

5-1/2" X 2-7/8"

Manual No:
DL-324X-5500-1694

Revision: **A**

Revision Date:
08/01/2023

Authored by: J.Anderson

Approved by: E.Visaez

D) PRE-INSTALLATION INSPECTION PROCEDURES (cont'd)

GENERAL SCREW TORQUE RECOMMENDATIONS									
SCREW SIZE (INCHES)	#6	#8	#10	1/4	5/16	3/8	7/16	1/2	5/8 and larger
TORQUE RANGE (INCH-POUNDS)	5 – 8	10 – 15	18 – 25	25 – 40	50 – 80	90 – 135	160 – 210	250 – 330	450 - 650

Before first use, D&L recommends disassembly and inspection of the tool unless stated otherwise. Ensure parts have not been damaged during shipping. Replace damaged parts with D&L replacement parts. Contact D&L sales for replacement part information.

Re-assemble the tool after inspection. Install parts in the correct order and orientation. Properly tighten connections.

Before re-using the tool, D&L recommends disassembly and inspection of the tool. Clean parts and ensure parts are in good working condition. Replace worn or damaged parts with D&L replacement parts.

When redressing the tool, D&L recommends replacement of all seals, o-rings, shear screws, etc. Contact D&L sales for redress kit and/or other replacement part information.

E) SETTING AREA GUIDE

SIZE (INCHES)	SETTING AREA (SQ INCHES)	SHEAR VALUE (PSI/SCREW)	SETTING INITIATION PRESSURE (PSI)	RECOMMENDED SETTING PRESSURE (PSI)
5-1/2	5.048	436	3,488	3,300

F) SETTING PROCEDURES

CAUTION: Do not run the tool without properly tightening connections. Running the tool with loose connections may damage the tool and cause malfunction.

The Hydro-X Tubing Anchor is operated by applying pressure to the tubing. The applied pressure shears the setting shear screws which set the anchor. The setting piston sets the slips set while locking the setting force in place.

A tubing plug (ball seat, pump-out plug, etc.) must be run below the anchor so pressure can be applied to the tubing. The initial setting pressure is controlled by shear screws in the setting piston. The shear screws are rated to 436 psi per screw and the pressure to initiate setting will be determined by the quantity of shear screws.

G) RELEASING PROCEDURES

A straight pull shears the releasing shear screws with tension and the anchor can be retrieved. The anchor must be re-dressed before it can be reset. Shear screws are added in 5,000 lb increments up to a maximum of 60,000 lbs to achieve the desired shear value necessary to release the anchor.

H) ELASTOMER TRIM TEMPERATURE GUIDE

RUBBER TYPE	TEMPERATURE RANGE
NITRILE	40° - 250°F
HSN (HNBR)	70° - 300°F
VITON	100° - 350°F



HYDRO-X TUBING ANCHOR

5-1/2" X 2-7/8"

Manual No:
DL-324X-5500-1694

Revision: **A**

Revision Date:
08/01/2023

Authored by: J.Anderson

Approved by: E.Visaez

I) STORAGE RECOMMENDATIONS

When preparing the tool for storage, follow the Pre-Installation Inspection Procedures. Re-assemble the tool with connections hand-tight only and in running position if applicable.

Store the tool, if possible, in an enclosed, temperature and humidity controlled environment. Avoid excessively high temperatures over long periods of time. Keep tool dry and protected from condensation. Do not store in contact with or near volatile or corrosive chemicals. Do not store near ozone generating equipment or operations such as welding.

J) RECOMMENDED HAND TOOLS

- VISE
- GLOVES
- ALLEN WRENCHES
- TAPE MEASURE
- O-RING PICK
- BAR
 - 1/2-INCH
 - 3/4-INCH
- PAINT BRUSH, 2-INCH
- PIPE WRENCH, 3-FT (2 EA)
- "CHEATER" PIPE, 4-FT LONG
- ADJUSTABLE WRENCH, 12-INCH
- CORDLESS DRILL, 18V
- SNAP RING SPREADER PLIERS
- ALIGNING PUNCH
- SCREWDRIVER SET, FLAT-TIPPED
- SOCKET SETS
 - 3/8-INCH DRIVE
 - 1/2-INCH DRIVE
- HAMMERS
 - SLEDGE
 - BALL PEEN
 - DEAD BLOW

K) DISASSEMBLY

K-1) Clamp top sub (1) in vise.

K-1.1) From lower end of tool, unscrew and remove shear screws (15) from lower cone (10).

K-1.2) Unscrew and remove set screws (14) from slip body (8).

K-1.3) Wedge slips (9) outward (if needed). Remove slip body assembly from inner mandrel (2) and disassemble:

K-1.3.1) Remove wedges (if needed). Remove slips assemblies from slip body (8) and disassemble:

K-1.3.1.1) Unscrew and remove button head screws (12) from slips (9).

K-1.3.1.2) Remove slip springs (13) from slips (9).

K-1.3.2) Remove lower cone (10) from slip body (8).

K-2) Unclamp and remove top sub (1) from vice. Clamp on lower end of inner mandrel (2).

K-2.1) From upper end of tool, unscrew and remove top sub (1) from inner mandrel (2).

K-2.2) Unscrew and remove shear screws (16) from setting piston (5).

K-2.3) Remove shear cap (3) from setting piston (5) and inner mandrel (2).

K-2.3.1) Remove o-rings (18, 20) from shear cap (3).

K-2.4) Remove snap ring (4) from inner mandrel (2).

K-2.5) Unscrew and remove setting piston (5) from upper cone (7).

K-2.5.1) Remove o-ring (19) from setting piston (5).

K-2.6) Remove slip body cap (11) from upper cone (7).

K-2.7) Unscrew and remove shear screw (17) from upper cone (7).

K-2.8) Unscrew and remove upper cone (7) downward from lock ring (6).

K-2.9) Unscrew and/or slide lock ring (6) from inner mandrel (2) (**NOTE₁**: Left-hand threads).

NOTE₂: Using snap ring spreader pliers, the lock ring (6) may be spread slightly to be removed from inner mandrel (2).

K-2.10) Remove upper cone (7) from inner mandrel (2).

K-3) Unclamp and remove inner mandrel (2) from vise.



HYDRO-X TUBING ANCHOR

5-1/2" X 2-7/8"

Manual No:
DL-324X-5500-1694

Revision: **A**

Revision Date:
08/01/2023

Authored by: J.Anderson

Approved by: E.Visaez

L) ASSEMBLY

NOTE₃: Clean and inspect all parts. Replace all worn and damaged parts. Install parts in proper order and orientation.

L-1) Clamp lower end of inner mandrel (2) in vise.

L-1.1) Install upper cone (7) onto inner mandrel (2).

L-1.2) Screw and/or slide lock ring (6) onto inner mandrel (2) (**NOTE₁:** Left-hand threads).

NOTE₄: Threads on lock ring (6) are directional and must be installed in correct direction for tool to work properly.

L-1.3) Screw upper cone (7) onto lock ring (6). Align threaded hole in upper cone (7) with gap in lock ring (6).

L-1.4) Screw shear screw (17) into upper cone (7). Tighten until screw contacts mandrel (2). Back off 1/4 turn.

L-1.5) Install slip body cap (11) onto upper cone (7).

L-1.6) Install o-ring (19) in o-ring groove in setting piston (5).

L-1.7) Screw setting piston (5) onto upper cone (7).

CAUTION₁: Do not rip or tear o-ring during installation.

L-1.8) Install snap ring (4) in groove in inner mandrel (2).

L-1.9) Install o-rings (18, 20) in o-ring grooves in shear cap (3).

L-1.10) Install shear cap (3) into setting piston (5). Align groove in shear cap (3) with threaded holes in setting piston (5).

CAUTION₁: Do not rip or tear o-rings during installation.

L-1.11) Screw shear screws (16) into setting piston (5). Tighten until shear screws (16) contact shear cap (3). Back shear screws (16) out 1/4 turn.

L-1.12) Screw top sub (1) onto inner mandrel (2).

L-2) Unclamp and remove inner mandrel (2) from vise. Clamp top sub (1) in vise.

L-2.1) Assemble slip body assembly and install:

L-2.1.1) Install lower cone (10) into slip body (8).

L-2.1.2) Assemble slip assemblies and install into slip body (8).

L-2.1.2.1) Install slip springs (13) in place on slips (9).

NOTE₈: Install two (2 ea) springs per slip (Fig. 2).

L-2.1.2.2) Screw button head screws (12) into slips (9).

L-2.1.2.3) Install slip assemblies into slip body (8).

L-2.1.3) Wedge slips (9) outward. Install slip body assembly onto inner mandrel (2).

L-2.2) Screw slip body cap (11) onto slip body (8).

L-2.3) Screw set screws (14) into slip body (8). Remove wedges.

L-2.4) Align threaded holes of lower cone (10) with counterbores in inner mandrel (2).

L-2.5) Screw shear screws (15) into lower cone (10). Tighten until shear screws (15) contact inner mandrel (2). Back shear screws (15) out 1/4 turn.

L-3) Unclamp top sub (1) from vise and remove assembled tool.



Fig. 2



HYDRO-X TUBING ANCHOR

5-1/2" X 2-7/8"

Manual No:
DL-324X-5500-1694

Revision: **A**

Revision Date:
08/01/2023

Authored by: J.Anderson

Approved by: E.Visaez

M) PARTS LIST

ITEM	QTY	DESCRIPTION	MATERIAL	P/N 324X55
1	1	COUPLING	DLMS80	CP-BAC-B
2	1	INNER MANDREL	DLMS80	324X55210
3	1	SHEAR CAP	DLMS80	324X55740
4	1	STOP RING	DLMS110	32455980
5	1	SETTING PISTON	DLMS80	324X55750
6	1	LOCK NUT	DLMS80	32455011
7	1	UPPER CONE	DLMS110	324X55410
8	1	SLIP BODY	DLMS80	324X55320
9	4	SLIP	DLMS35	32055112
10	1	LOWER CONE	DLMS110	324X55420
11	1	SLIP CAGE CAP	DLMS80	324X55321
12	4	#8-32 UNC X 3/8 BUTTON HEAD SOCKET CAP SCREW	STEEL	BHSC832C037
13	8	SLIP SPRING	INCONEL 625	32055950
14	3	3/8-16 UNC X 1/4 SOCKET SET SCREW	STEEL	SSS037C025
15	12	SHEAR SCREW	DLM360BRS	32045910
16	8	5/16-24 UNF X 5/16 SLOTTED SHEAR SCREW (2200#)	DLM360BRS	BSSSLT031F031
17	1	#10-32 UNF X 1/4 SLOTTED SHEAR SCREW (750#)	DLM360BRS	BSSSLT1032F025
18	1	235 O-RING	90 DURO NITRILE	90235
19	1	338 O-RING	90 DURO NITRILE	90338
20	1	342 O-RING	90 DURO NITRILE	90342

REDRESS KIT (RDK)		324X55050
ASSEMBLED WEIGHT		89 LBS



HYDRO-X TUBING ANCHOR

5-1/2" X 2-7/8"

Manual No:
DL-324X-5500-1694

Revision: **A**

Revision Date:
08/01/2023

Authored by: J.Anderson

Approved by: E.Visaez

M) PARTS LIST (cont'd0)

M-1) ELASTOMER TRIM OPTIONS

NOTE₇: For temperature range, refer to Elastomer Trim Temperature Guide.

M-1.1) HSN

ITEM	QTY	DESCRIPTION	MATERIAL	P/N 324X55H
18	1	235 O-RING	90 DURO HSN	90235H
19	1	338 O-RING	90 DURO HSN	90338H
20	1	342 O-RING	90 DURO HSN	90342H

REDRESS KIT (RDK)		324X55050H
-------------------	--	------------

M-1.2) VITON

ITEM	QTY	DESCRIPTION	MATERIAL	P/N 324X55V
18	1	235 O-RING	90 DURO VITON	90235V
19	1	338 O-RING	90 DURO VITON	90338V
20	1	342 O-RING	90 DURO VITON	90342V

REDRESS KIT (RDK)		324X55050V
-------------------	--	------------



HYDRO-X TUBING ANCHOR

5-1/2" X 2-7/8"

Manual No:
DL-324X-5500-1694

Revision: **A**

Revision Date:
08/01/2023

Authored by: *J.Anderson*

Approved by: *E.Visaez*

N) TECHNICAL ILLUSTRATION

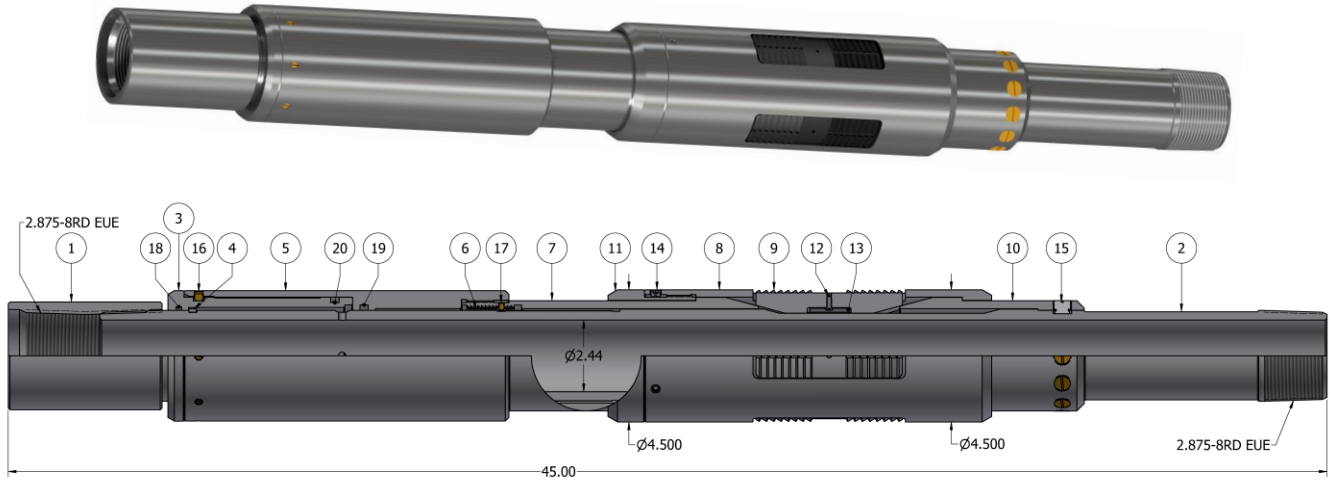

O) REVISION HISTORY

DATE	REVISION	DESCRIPTION OF CHANGES	REVISED BY	APPROVED BY
08/01/2023	A	Created manual	-	-