



ON/OFF TOOL AND PROFILE STINGER 2-7/8"

Manual No:
DL-515-2875-1027

Revision: **B**

Revision Date:
07/23/2021

Authored by: J.Anderson

Approved by: H.Bringham

A) DESCRIPTION

The On/Off Tool is a tubing seal receptacle allowing isolation of a lower zone using a wireline blanking plug. The tubing string can then be removed from the well. When re-run, the tubing string automatically re-engages to the stinger, and the blanking plug can be retrieved by wireline.

The On/Off Tool is run above an ASI-X Packer, a VSI-X Packer or a Permapak Seal Bore Packer with a latch seal mandrel.

NOTE₁: Stinger must be purchased separately.

B) RELATED TOOLS (sold separately)

B-1) ASI-X, VSI-X and Permanent Packers—refer to applicable technical manual.

C) SPECIFICATION GUIDE

SIZE (INCHES)	TOOL OD (INCHES)	TOOL ID (INCHES)	THREAD CONNECTION BOX UP	PART NUMBER
5-1/2 (23.0 – 26.0#)	4.406	2.50	2-7/8 EUE	51551 51551H ¹ 51551V ²
5-1/2	4.500	2.50	2-7/8 EUE	51556 51556H ¹ 51556V ²
6-5/8	5.500	2.50	2-7/8 EUE	51566 51566H ¹ 51566V ²
7	5.875	2.50	2-7/8 EUE	51571 51571H ¹ 51571V ²
7-5/8	6.380	2.50	2-7/8 EUE	51575 51575H ¹ 51575V ²
8-5/8	7.500	2.50	2-7/8 EUE	51585 51585H ¹ 51585V ²
9-5/8	8.250	2.50	2-7/8 EUE	51595 51595H ¹ 51595V ²
11-3/4	10.000	2.50	2-7/8 EUE	51511B 51511BH ¹ 51511BV ²

Elastomer Trim Options: ¹HSN, ²Viton

NOTE₂: Additional sizes available—contact D&L Oil Tools for more information.

D & L OIL TOOLS
P.O. BOX 52220 TULSA, OK 74152
PHONE: (800) 441-3504 www.dloilttools.com



ON/OFF TOOL AND PROFILE STINGER 2-7/8"

Manual No:
DL-515-2875-1027

Revision: **B**

Revision Date:
07/23/2021

Authored by: J.Anderson

Approved by: H.Bringham

C) SPECIFICATION GUIDE (cont'd)

DIFFERENTIAL PRESSURE (MAX)	NUMBER OF LUGS ON STINGER	STINGER METALLURGY*	STINGER SAFE WORKING TENSILE LOAD	STINGER LUG SHEAR RATING
10,000 PSI	2	DLMS80 (80,000 PSI MIN.)	58,300 LBS	72,884 LBS

*Other metallurgy available. Contact D&L Engineering for more information.

D) PRE-INSTALLATION INSPECTION PROCEDURES

CAUTION₁: D&L ships tool connections made-up **HAND TIGHT**—labeled with hand-tight tape on the tool (Fig. 1)—unless stated otherwise. Tighten/torque all connections properly before operating tool (600 – 800 ft-lbs is recommended for ACME threads).



Fig. 1

GENERAL SCREW TORQUE RECOMMENDATIONS									
SCREW SIZE (IN)	#6	#8	#10	1/4	5/16	3/8	7/16	1/2	5/8 and larger
TORQUE RANGE (IN-LBS)	5 – 8	10 – 15	18 – 25	25 – 40	50 – 80	90 – 135	160 – 210	250 – 330	450 - 650

Before first use, D&L recommends disassembly and inspection of the tool unless stated otherwise. Ensure parts have not been damaged during shipping. Replace damaged parts with D&L replacement parts. Contact D&L sales for replacement part information.

Re-assemble the tool after inspection. Install parts in the correct order and orientation. Properly tighten connections.

Before re-using the tool, D&L recommends disassembly and inspection of the tool. Clean parts and ensure parts are in good working condition. Replace worn or damaged parts with D&L replacement parts.

When redressing the tool, D&L recommends replacement of all seals, o-rings, etc. Contact D&L sales for redress kit and/or other replacement part information.

E) OPERATING PROCEDURES

CAUTION₂: Do not run the tool without properly tightening connections. Running the tool with loose connections may damage the tool and cause malfunction.

E-1) WHEN USED WITH A MECHANICAL SET ASI-X PACKER

E-1.1) IN COMPRESSION

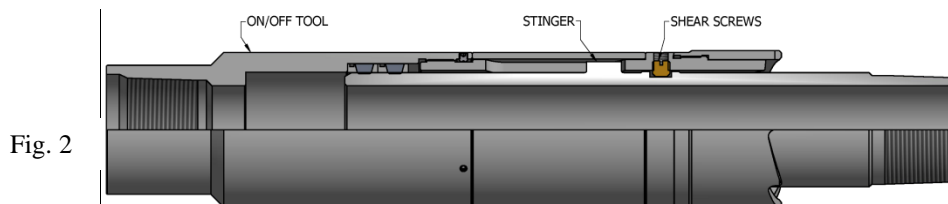

Fig. 2

Pin the overshot to the stinger in the compression position (Fig. 2). Run the tool to the desired depth. Pick up and set down holding right-hand torque. Release the torque once the tool begins its setting procedure. Continue to set down to shear the pin and rotate to the left to release the overshot from the stinger.



ON/OFF TOOL AND PROFILE STINGER 2-7/8"

Manual No:
DL-515-2875-1027

Revision: B

Revision Date:
07/23/2021

Authored by: J.Anderson

Approved by: H.Bringham

E) OPERATING PROCEDURES (cont'd)

E-1.2) IN TENSION

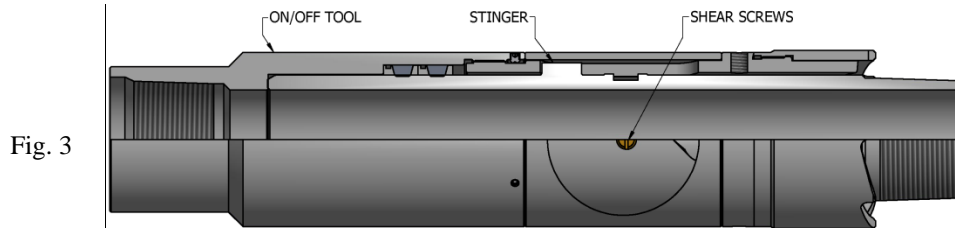

Pin the overshoot to the stinger in the tension position (Fig. 3). Run in the tool to the desired depth. Pick up and set down holding right-hand torque. Release the torque once the tool begins its setting procedure. Once the ASI-X is completely set, straight pull to shear the pin and rotate to the left to release the overshoot from the stinger.

F) RETRIEVING AND RESETTING

Run in the D&L Overshot Tool to just above stinger depth. Then as the tool tags the stinger, the pins on the stinger will engage the J-slot. As the D&L Overshot Tool rotates, the pins will enter the running slot. Run the D&L Overshot Tool in until it is completely on the stinger. Continue to set down on the packer and when the tool takes weight, begin to create right-hand torque. The ASI-X Packer will disengage and can be reset at a different depth, or retrieved.

Use the setting procedure for the ASI-X Packer to reset it. After the ASI-X Packer is reset, the D&L Overshot Tool will release from the stinger by pulling with left-hand torque and releasing from the stinger.

G) PROFILE STINGER



The 2-7/8" stinger is available in a variety of profiles that range from 1.50" to 2.31" (Fig. 4). The stinger is also available in a solid, and a full open that is available up to 2.50".

H) STORAGE RECOMMENDATIONS

When preparing the tool for storage, follow the Pre-Installation Inspection Procedures. Re-assemble the tool with connections hand-tight only and in running position if applicable.

Store the tool, if possible, in an enclosed, temperature and humidity controlled environment. Avoid excessively high temperatures over long periods of time. Keep tool dry and protected from condensation. Do not store in contact with or near volatile or corrosive chemicals. Do not store near ozone generating equipment or operations such as welding.



ON/OFF TOOL AND PROFILE STINGER 2-7/8"

Manual No:
DL-515-2875-1027

Revision: B

Revision Date:
07/23/2021

Authored by: J.Anderson

Approved by: H.Bringham

I) ELASTOMER TRIM TEMPERATURE GUIDE

RUBBER TYPE	TEMPERATURE RANGE
NITRILE	40° - 250°F
HSN (HNBR)	70° - 300°F
VITON	100° - 350°F

J) RECOMMENDED HAND TOOLS

- VISE
- GLOVES
- ALLEN WRENCHES
- TAPE MEASURE
- O-RING PICK
- BAR
 - 1/2-INCH
 - 3/4-INCH
- PAINT BRUSH, 2-INCH
- PIPE WRENCH, 3-FT (2 EA)
- "CHEATER" PIPE, 4-FT LONG
- ADJUSTABLE WRENCH, 12-INCH
- CORDLESS DRILL, 18V
- SNAP RING SPREADER PLIERS
- ALIGNING PUNCH
- SCREWDRIVER SET, FLAT-TIPPED
- SOCKET SETS
 - 3/8-INCH DRIVE
 - 1/2-INCH DRIVE
- HAMMERS
 - SLEDGE
 - BALL PEEN
 - DEAD BLOW

K) DISASSEMBLY

- K-1) Clamp top sub (1) in vise.
- K-1.1) Unscrew and remove shoe (4) from J-body (2).
- K-1.2) Unscrew and remove set screws (6) from top sub (1).
- K-1.3) Unscrew and remove J-body (2) from top sub (1).
- K-1.4) Remove J-body cover (5) from J-body (2).
- K-1.5) Remove seals (3) from top sub (1).
- K-1.5.1) Remove o-rings (7) from seals (3).
- K-2) Unclamp and remove top sub (1) from vise.

L) ASSEMBLY

NOTE: Clean and inspect all parts. Replace all worn and damaged parts. Install parts in proper order, and orientation and tighten/torque all connections properly.

- L-1) Clamp top sub (1) in vise.
- L-1.1) Install o-rings (7) in grooves in seals (3).
- L-1.2) Install seals (3) into top sub (1).
- CAUTION:** Do not rip or tear o-rings during installation.
- L-1.3) Install J-body cover (5) onto J-body (2).
- L-1.4) Screw J-body (2) into top sub (1).
- L-1.5) Screw set screws (6) into top sub (1).
- L-1.6) Screw shoe (4) onto J-body (2).
- L-2) Unclamp top sub (1) from vise and remove assembled tool.



ON/OFF TOOL AND PROFILE STINGER 2-7/8"

Manual No:
DL-515-2875-1027

Revision: **B**

Revision Date:
07/23/2021

Authored by: J.Anderson

Approved by: H.Bringham

M) PARTS LIST

ITEM	QTY	DESCRIPTION	MATERIAL	P/N 51551	P/N 51556	P/N 51566	P/N 51571	P/N 51575	P/N 51585	P/N 51595	P/N 51511B
1	1	TOP SUB	DLMS80	51251610							
2	1	J-BODY	DLMS110	51556340A							
3	2	SEAL	90 DURO NITRILE	60070520							
4	1	MILLING SHOE	DLMS80	51551340C	51556340C	51566340C	51571340C	51575340C	51585340C	51595340C	51511345C
5	1	J-BODY COVER	DLMS60	51556340B							
6	3	SET SCREW 1/4-20 UNC X 1/4	STEEL	SSS025C025							
7	2	153 O-RING	90 DURO NITRILE	90153							

Optional shear screws: BSSSLT050C050/BSSSLT050C043 (2 qty) – Rated at 5,500# per screw

REDRESS KIT (RDK)	51556050	51556050	51566050	51571050	51575050	51585050	51595050	51511B050
ASSEMBLED WEIGHT	29 LBS	30 LBS	31 LBS	32 LBS	34 LBS	36 LBS	39 LBS	48 LBS



ON/OFF TOOL AND PROFILE STINGER 2-7/8"

Manual No:
DL-515-2875-1027

Revision: **B**

Revision Date:
07/23/2021

Authored by: J.Anderson

Approved by: H.Bringham

M-1) ELASTOMER TRIM OPTIONS

NOTE4: For temperature range, refer to Elastomer Trim Temperature Guide.

M-1.1) HSN

ITEM	QTY	DESCRIPTION	MATERIAL	P/N 51551H	P/N 51556H	P/N 51566H	P/N 51571H	P/N 51575H	P/N 51585H	P/N 51595H	P/N 51511BH
3	2	SEAL	90 DURO HSN	60070520H							
7	2	153 O-RING	90 DURO HSN	90153H							

REDRESS KIT (RDK)	51556050H	51556050H	51566050H	51571050H	51575050H	51585050H	51595050H	51511B050H
-------------------	-----------	-----------	-----------	-----------	-----------	-----------	-----------	------------

M-1.2) VITON

ITEM	QTY	DESCRIPTION	MATERIAL	P/N 51551V	P/N 51556V	P/N 51566V	P/N 51571V	P/N 51575V	P/N 51585V	P/N 51595V	P/N 51511BV
3	2	SEAL	90 DURO VITON	60070520V							
7	2	153 O-RING	90 DURO VITON	90153V							

REDRESS KIT (RDK)	51556050V	51556050V	51566050V	51571050V	51575050V	51585050V	51595050V	51511B050V
-------------------	-----------	-----------	-----------	-----------	-----------	-----------	-----------	------------



ON/OFF TOOL AND PROFILE STINGER

2-7/8"

Manual No:
DL-515-2875-1027

Revision: **B**

Revision Date:
07/23/2021

Authored by: J.Anderson

Approved by: H.Bringham

N) TECHNICAL ILLUSTRATION

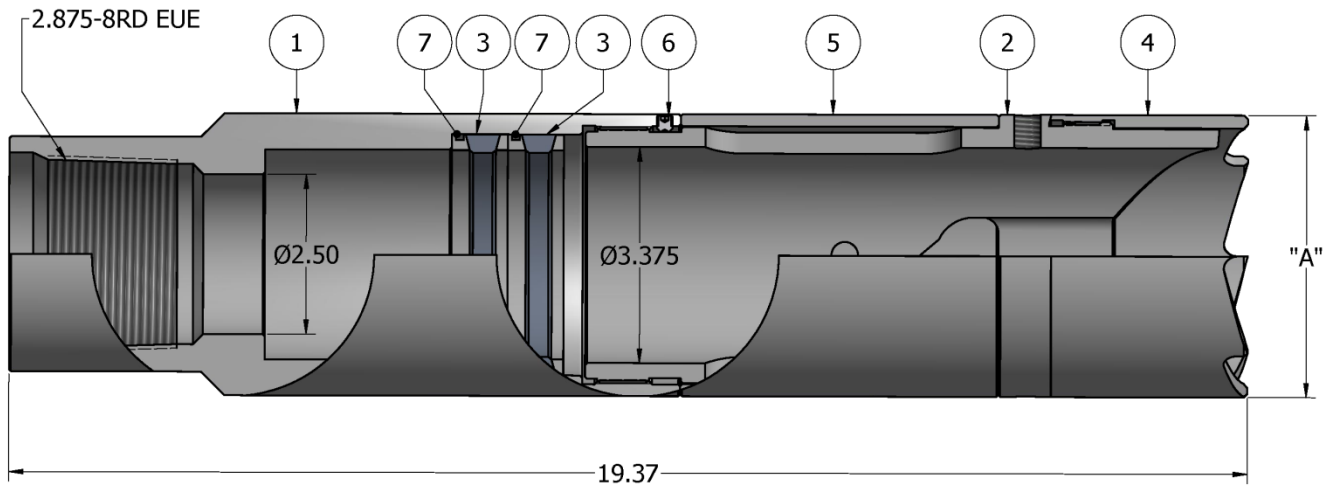
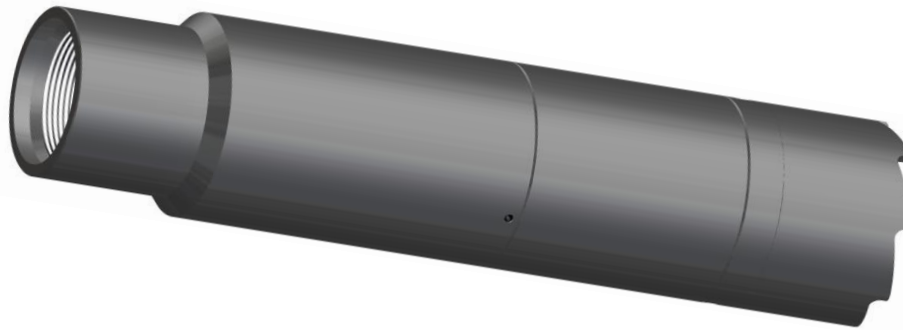

**DIMENSIONAL DATA
(INCHES)**

	5-1/2" (23.0 – 26.0#)	5-1/2"	6-5/8"	7"	7-5/8"	8-5/8"	9-5/8"	11-3/4"
"A"	4.406	4.500	5.500	5.875	6.380	7.500	8.250	10.000



ON/OFF TOOL AND PROFILE STINGER 2-7/8"

Manual No:
DL-515-2875-1027

Revision: **B**

Revision Date:
07/23/2021

Authored by: J.Anderson

Approved by: H.Bringham

O) REVISION HISTORY

DATE	REVISION	DESCRIPTION OF CHANGES	REVISED BY	APPROVED BY
07/23/2021	B	Revised nitrile temp. rating; Added optional P/N BSSSLT050C043	J.Anderson	E.Visaez
02/20/2017	A	Created new manual	-	-