



SAFETY SHEAR JOINTS

1.660” – 5-1/2”

Manual No:
DL-569-0000-016

Revision: **D**

Revision Date:
06/22/2015

Authored by: B.Mathis

Approved by: D.Hushbeck

A) DESCRIPTION

The Safety Shear Joint allows positive release of the tubing string in completions where retrieval problems are anticipated.

Safety shear joints are designed to release with a straight pull. Screws may be removed to reduce the shear release force. These safety shear joints are keyed so torque through the tool does not load the shear screws. (Non-keyed versions are also available).

B) SPECIFICATION GUIDE

SIZE (INCHES)	TOOL OD (INCHES)	THREAD CONNECTION BOX UP / PIN DOWN	PART NUMBER
1.660	2.060	1.660” NUE	56916N 56916NH ¹ 56916NV ²
1.900	2.300	1.900” NUE	56919N 56919NH ¹ 56919NV ²
		1.900” EUE	56919E 56919EH ¹ 56919EV ²
2-3/8	3.060	2-3/8” EUE	56920K 56920KH ¹ 56920KV ²
2-7/8	3.688	2-7/8” EUE	56927K 56927KH ¹ 56927KV ²
3-1/2	4.500	3-1/2” EUE	56935K 56935KH ¹ 56935KV ²
4	5.000	4” EUE	56940K 56940KH ¹ 56940KV ²
4-1/2	5.560	4-1/2” EUE	56945K 56945KH ¹ 56945KV ²
5	5.560	5” LTC	56950K 56950KH ¹ 56950KV ²
5-1/2	6.050	5-1/2” LTC	56955K 56955KH ¹ 56955KV ²

Elastomer Trim Options: ¹HSN, ²Viton



SAFETY SHEAR JOINTS

1.660” – 5-1/2”

Manual No:
DL-569-0000-016

Revision: **D**

Revision Date:
06/22/2015

Authored by: *B.Mathis*

Approved by: *D.Hushbeck*

C) PRE-INSTALLATION INSPECTION PROCEDURES

Before first use, D&L recommends disassembly and inspection of the tool unless stated otherwise. Ensure parts have not been damaged during shipping. Replace damaged parts with D&L replacement parts. Contact D&L sales for replacement part information.

Re-assemble the tool after inspection. Install parts in the correct order and orientation.

Before re-using the tool, D&L recommends disassembly and inspection of the tool. Clean parts and ensure parts are in good working condition. Replace worn or damaged parts with D&L replacement parts.

When redressing the tool, D&L recommends replacement of all o-rings, shear screws, etc. Contact D&L sales for redress kit and/or other replacement part information.

D) RELEASING PROCEDURES

A straight pull shears the shear screws and releases the top sub and work string above it. The releasing force is calculated by the following formula: (Qty of Shear Screws) X (Shear Value per Screw) = Release Force

Example: (8 screws) X (4375 lbs/screw) = 35,000 lbs

E) STORAGE RECOMMENDATIONS

When preparing the tool for storage, follow the Pre-Installation Inspection Procedures.

Store the tool, if possible, in an enclosed, temperature and humidity controlled environment. Avoid excessively high temperatures over long periods of time. Shield elastomeric parts from ultraviolet light sources. Keep tool dry and protected from condensation. Do not store in contact with or near volatile or corrosive chemicals. Do not store near ozone generating equipment or operations such as welding.

F) ELASTOMER TRIM TEMPERATURE GUIDE

RUBBER TYPE	TEMPERATURE RANGE
NITRILE	70° - 300°F
HSN (HNBR)	70° - 325°F
VITON	100° - 350°F

G) RECOMMENDED HAND TOOLS

- VISE
- GLOVES
- ALLEN WRENCHES
- TAPE MEASURE
- O-RING PICK
- BAR
 - 1/2-INCH
 - 3/4-INCH
- PAINT BRUSH, 2-INCH
- PIPE WRENCH, 3-FT (2 EA)
- “CHEATER” PIPE, 4-FT LONG
- ADJUSTABLE WRENCH, 12-INCH
- CORDLESS DRILL, 18V
- SNAP RING SPREADER PLIERS
- ALIGNING PUNCH
- SCREWDRIVER SET, FLAT-TIPPED
- SOCKET SETS
 - 3/8-INCH DRIVE
 - 1/2-INCH DRIVE
- HAMMERS
 - SLEDGE
 - BALL PEEN
 - DEAD BLOW



SAFETY SHEAR JOINTS

1.660” – 5-1/2”

Manual No:
DL-569-0000-016

Revision: **D**

Revision Date:
06/22/2015

Authored by: B.Mathis

Approved by: D.Hushbeck

H) DISASSEMBLY

- H-1) Clamp top sub (1) in vise.
 - H-1.1) Unscrew and remove shear screws (3) from bottom sub (2).
 - H-1.2) Remove bottom sub (2) from top sub (1).
 - H-1.3) Remove o-rings (4) from bottom sub (2).
- H-2) Unclamp and remove top sub (1) from vise.

I) ASSEMBLY

- I-1) Clamp top sub (1) in vise.
 - I-1.1) Install o-rings (4) in o-ring groove(s) of bottom sub (2).
 - I-1.2) Install bottom sub (2) onto top sub (1).
 - CAUTION:** Do not rip or tear o-ring(s) during install.
 - I-1.3) Align threaded holes in bottom sub (2) with pocket holes in top sub (1).
 - I-1.4) Screw shear screws (3) into bottom sub (2). Tighten until shear screws make contact with top sub (1). Back shear screws out 1/4 turn.
- I-2) Unclamp top sub (1) from vise and remove assembled tool.

J) PARTS LIST

TOOL PART NUMBER	TOP SUB (ITEM 1)	BOTTOM SUB (ITEM 2)	SHEAR SCREW (ITEM 3)		O-RING (ITEM 4)	
			PART NUMBER	QUANTITY	PART NUMBER	QUANTITY
56916N	56916N610	56916N630	BSSSLT025C025	8	90222	1
56919N	56919N610	56919N630	BSSSLT031C031	8	90224	1
56919E	56919E610	56919E630	BSSSLT031C037	8	90224	1
56920K	56920K610	56920K630	BSSSLT043F043	12	90229	2
56927K	56927K610	56927K630	BSSSLT043F043	12	90233	2
56935K	56935K610	56935K630	BSSSLT043F043	12	90239	2
56940K	56940K610	56940K630	BSSSLT043F050	16	90243	2
56945K	56945K610	56945K630	BSSSLT043F050	20	90247	2
56950K	56950K610	56950K630	BSSSLT043F043	16	90249	2
26955K	56955K610	56955K360	BSSSLT043F043	16	90253	2



SAFETY SHEAR JOINTS

1.660” – 5-1/2”

Manual No:
DL-569-0000-016

Revision: **D**

Revision Date:
06/22/2015

Authored by: B.Mathis

Approved by: D.Hushbeck

J) PARTS LIST (cont'd)

TOOL PART NUMBER	ASSEMBLED WEIGHT	REDRESS KIT (RDK)
56916N	3 LBS	56916N050
56919N	4 LBS	56919N050
56919E	5 LBS	56919E050
56920K	10 LBS	56920K050
56927K	15 LBS	56927K050
56935K	24 LBS	56935K050
56940K	25 LBS	56940K050
56945K	29 LBS	56945K050
56950K	23 LBS	56950K050
26955K	32 LBS	56955K050

J-1) ELASTOMER TRIM OPTIONS

NOTE₄: For temperature range, refer to Elastomer Trim Temperature Guide.

J-1.1) HSN

TOOL PART NUMBER	O-RING (ITEM 4)		REDRESS KIT (RDK)
	PART NUMBER	QUANTITY	
56916NH	90222H	1	56916N050H
56919NH	90224H	1	56919N050H
56919EH	90224H	1	56919E050H
56920KH	90229H	2	56920K050H
56927KH	90233H	2	56927K050H
56935KH	90239H	2	56935K050H
56940KH	90243H	2	56940K050H
56945KH	90247H	2	56945K050H
56950KH	90249H	2	56950K050H
26955KH	90253H	2	56955K050H



SAFETY SHEAR JOINTS

1.660” – 5-1/2”

Manual No:
DL-569-0000-016

Revision: **D**

Revision Date:
06/22/2015

Authored by: *B.Mathis*

Approved by: *D.Hushbeck*

J) PARTS LIST (cont'd)

J-1.2) VITON

TOOL PART NUMBER	O-RING (ITEM 4)		REDRESS KIT (RDK)
	PART NUMBER	QUANTITY	
56916NV	90222V	1	56916N050V
56919NV	90224V	1	56919N050V
56919EV	90224V	1	56919E050V
56920KV	90229V	2	56920K050V
56927KV	90233V	2	56927K050V
56935KV	90239V	2	56935K050V
56940KV	90243V	2	56940K050V
56945KV	90247V	2	56945K050V
56950KV	90249V	2	56950K050V
26955KV	90253V	2	56955K050V



SAFETY SHEAR JOINTS

1.660" – 5-1/2"

Manual No:
DL-569-0000-016

Revision: **D**

Revision Date:
06/22/2015

Authored by: *B.Mathis*

Approved by: *D.Hushbeck*

K) TECHNICAL ILLUSTRATION

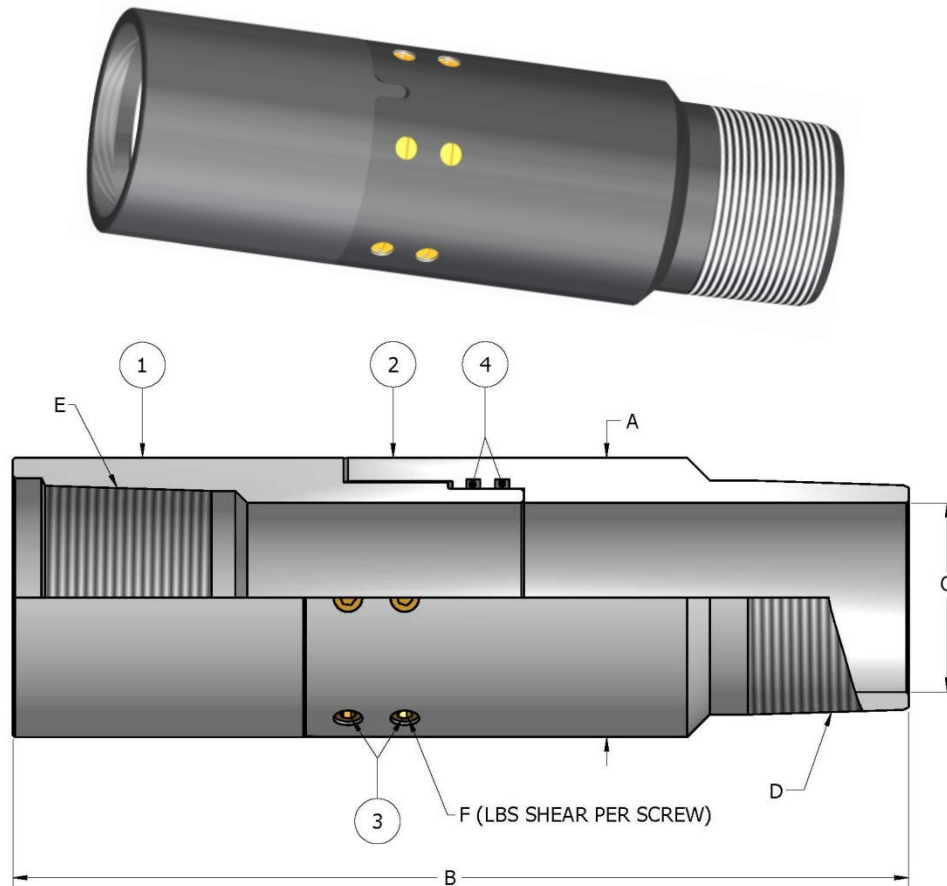

L) DIMENSIONS

TOOL PART NUMBER	A (INCHES)	B (INCHES)	C (INCHES)	D (PIN DOWN)	E (BOX UP)	F (LBS/SCREW)
56916N	2.060	7.41	1.25	1.660-10RD NUE	1.660-10RD NUE	1,200
56919N	2.300	7.44	1.50	1.900-10RD NUE	1.900-10RD NUE	2,000
56919E	2.500	7.44	1.50	1.900-10RD EUE	1.900-10RD EUE	2,200
56920K	3.060	11.19	2.00	2.375-8RD EUE	2.375-8RD EUE	4,300
56927K	3.688	11.84	2.50	2.875-8RD EUE	2.875-8RD EUE	4,300
56935K	4.500	12.69	3.00	3.500-8RD EUE	3.500-8RD EUE	4,300
56940K	5.000	11.94	3.50	4.000-8RD EUE	4.000-8RD EUE	4,300
56945K	5.560	11.94	4.00	4.500-8RD EUE	4.500-8RD EUE	4,300
56950K	5.560	12.84	4.50	5.000-8RD STC	5.000-8RD LTC	4,300
26955K	6.050	13.97	4.67	5.500-8RD LTC	5.500-8RD LTC	4,300



SAFETY SHEAR JOINTS

1.660” – 5-1/2”

Manual No:
DL-569-0000-016

Revision: **D**

Revision Date:
06/22/2015

Authored by: *B.Mathis*

Approved by: *D.Hushbeck*

M) REVISION HISTORY

DATE	REVISION	DESCRIPTION OF CHANGES	REVISED BY	APPROVED BY
06/22/2015	D	Added P/N 56919E, 56945K, 56955K, Pre-Installation Inspection Procedures, Storage Recommendations, Elastomer Trim Temperature Guide, Recommended Hand Tools; Revised P/N 90222 was 90220, BSSSLT025C025 was BSS025C025 Removed P/N 56941K	J.Anderson	K.Riggs