



HD RETRIEVABLE PACKER RIGHT-HAND MANUAL

8-5/8" X 3-1/2", NC 50 TOOL JOINT

Manual No:
DL-613-8625-1662

Revision: **A**

Revision Date:
03/28/2023

Authored by: *J.Anderson*

Approved by: *E.Visaez*

A) DESCRIPTION

The HD Retrievable Packer is a heavy duty service packer ideally suited for all types of squeeze cementing, formation fracturing, high pressure acidizing, etc. It is a large opening compression set packer with hydraulic button-type hold down. This packer withstands high pressure from above or below and uses a 3-element packing system, J-slot, and a drag block mechanism for easy setting. This packer has a built-in unloader which circulates across the hydraulic hold down buttons to improve retrievability and run in performance.

B) SPECIFICATION GUIDE

CASING			TOOL			PART NUMBER
SIZE (INCHES)	WEIGHT (LBS/FT)	RECOMMENDED HOLE SIZE (INCHES)	GAGE OD (INCHES)	NOMINAL ID (INCHES)	THREAD CONNECTIONS BOX UP / PIN DOWN	
8-5/8	24.0 – 40.0	7.725- 8.097	7.500 7.504*	3.00	NC 50 TOOL JOINT	61387RM-XBEE 61387RMH ¹ -XBEE 61387RMV ² -XBEE

Elastomer Trim Options: ¹HSN, ²Viton

* Max OD across retracted drag blocks.

NOTE₁: Tools listed are right-hand auto set / straight pick-up.

DIFFERENTIAL PRESSURE (MAX)	TENSILE LOAD THRU UNSET TOOL (MAX)	HANGING WEIGHT ON SET TOOL (MAX)*	TORQUE THRU TOOL (MAX)
10,000 PSI	136,000 LBS	136,000 LBS *	2,000 FT-LBS

*Casing must be cemented for this load rating.

CAUTION₁: Before running the tool, check the pressure affected areas chart and consider other effects to be certain that the unloader will remain closed during operation.

CAUTION₂: If the HD Packer is run with a retrievable bridge plug, make sure the bridge plug J-slot is compatible with the J-slot on the packer. Whichever direction you set the plug, the packer should set in the **opposite** direction.

C) PRE-INSTALLATION INSPECTION PROCEDURES

CAUTION₃: D&L ships tool connections made-up hand-tight—labeled with hand-tight tape on the tool—unless stated otherwise. Properly tighten connections before operating tool (Fig. 1).



Fig. 1

GENERAL THREAD CONNECTION TORQUE RECOMMENDATIONS			
STUB ACME / ACME THREADS	INTERNAL TAPERED TUBING THREADS		PREMIUM THREADS
	UP TO 2-3/8"	GREATER THAN 2-3/8"	
600 – 800 FT-LBS	600 – 800 FT-LBS	800 – 1,200 FT-LBS	Consult thread manufacturer's recommendations.

D & L OIL TOOLS
P.O. BOX 52220 TULSA, OK 74152
PHONE: (800) 441-3504 www.dloiltools.com



HD RETRIEVABLE PACKER RIGHT-HAND MANUAL

8-5/8" X 3-1/2", NC 50 TOOL JOINT

Manual No:
DL-613-8625-1662

Revision: **A**

Revision Date:
03/28/2023

Authored by: J.Anderson

Approved by: E.Visaez

C) PRE-INSTALLATION INSPECTION PROCEDURES (cont'd)

GENERAL SCREW TORQUE RECOMMENDATIONS									
SCREW SIZE (INCHES)	#6	#8	#10	1/4	5/16	3/8	7/16	1/2	5/8 and larger
TORQUE RANGE (INCH-POUNDS)	5 – 8	10 – 15	18 – 25	25 – 40	50 – 80	90 – 135	160 – 210	250 – 330	450 - 650

Before first use, D&L recommends disassembly and inspection of the tool unless stated otherwise. Ensure parts have not been damaged during shipping. Replace damaged parts with D&L replacement parts. Contact D&L sales for replacement part information.

Re-assemble the tool after inspection. Install parts in the correct order and orientation. Properly tighten connections.

Before re-using the tool, D&L recommends disassembly and inspection of the tool. Clean parts and ensure parts are in good working condition. Replace worn or damaged parts with D&L replacement parts.

When redressing the tool, D&L recommends replacement of all seals, elements, o-rings, shear screws, etc. Contact D&L sales for redress kit and/or other replacement part information.

D) SETTING PROCEDURES

CAUTION4: Do not run the tool without properly tightening connections. Running the tool with loose connections may damage the tool and cause malfunction.

Run to setting depth. The unloader remains open while running in. Pick up the work string and rotate 1/4 right-hand turn at the packer. Slack off weight and set down on the packer to set the slips, close the unloader and compress the packing elements. A minimum weight of 18,000 lbs at the packer is required to pack off the elements.

CAUTION5: Run the tool slowly, as with any hold down type packer, to help prevent dulling of the hydraulic buttons.

E) RELEASING PROCEDURES

Pick up on the work string to open the unloader, allowing time for the tubing and casing pressure to equalize. Refer to Pressure Affected Area Guide to determine weight in addition to pipe weight required to pick up on packer. Continued upward movement of the work string unsets the slips, relaxes the packing elements. Rotate to the left 1/4 turn at the packer to return the J-pin to the running position. The tool may now be moved and reset or pulled from the well.

F) STORAGE RECOMMENDATIONS

When preparing the tool for storage, follow the Pre-Installation Inspection Procedures. Re-assemble the tool with connections hand-tight only and in running position if applicable. Elastomers should be in a relaxed state—free from tension, compression, and other stresses that could cause deformation.

Store the tool, if possible, in an enclosed, temperature and humidity controlled environment. Avoid excessively high temperatures over long periods of time. Shield elastomeric parts from ultraviolet light sources. Keep tool dry and protected from condensation. Do not store in contact with or near volatile or corrosive chemicals. Do not store near ozone generating equipment or operations such as welding.



HD RETRIEVABLE PACKER RIGHT-HAND MANUAL 8-5/8" X 3-1/2", NC 50 TOOL JOINT

Manual No:
DL-613-8625-1662

Revision: **A**

Revision Date:
03/28/2023

Authored by: *J.Anderson*

Approved by: *E.Visaez*

G) PRESSURE AFFECTED AREA GUIDE

When set downhole, the packer mandrel is subjected to a force created by differential pressure above or below the packer that acts on the pressure affected area (i.e., the piston effect). Depending on the tubing size and weight and the seal area of the packer the force created by differential pressure acts upwards or downwards on the packer mandrel. An upward force, designated as a negative (-) value, acts to push the packer mandrel up hole and must be accounted for to ensure that the packer remains set. A downward force, designated as a positive value, acts to push the packer mandrel down hole and must be accounted for when releasing the packer. Other factors (e.g., tubing movement due to temperature change) must be considered separately to determine all the forces acting on the packer.

PACKER SIZE (IN)	TUBING TO PACKER			PRESSURE AFFECTED AREA (IN ²)	
	SIZE (IN)	WEIGHT (LBS/FT)	ID (IN)		
				ABOVE	BELOW
8-5/8	1.900	2.40	1.650	6.922 (DOWN)	3.350 (DOWN)
		2.90	1.610	6.922 (DOWN)	3.247 (DOWN)
	2.375	4.00	2.041	5.327 (DOWN)	4.483 (DOWN)
		4.70	1.995	5.327 (DOWN)	4.337 (DOWN)
		5.95	1.867	5.327 (DOWN)	3.949 (DOWN)
	2.875	6.50	2.441	3.265 (DOWN)	5.891 (DOWN)
		7.90	2.323	3.265 (DOWN)	5.450 (DOWN)
		8.70	2.259	3.265 (DOWN)	5.219 (DOWN)
	3.500	7.70	3.068	0.136 (DOWN)	8.604 (DOWN)
		9.30	2.992	0.136 (DOWN)	8.242 (DOWN)
		10.20	2.922	0.136 (DOWN)	7.917 (DOWN)
		12.95	2.750	0.136 (DOWN)	7.151 (DOWN)
	4.000	9.50	3.548	-2.809 (UP)	11.098 (DOWN)
		11.00	3.476	-2.809 (UP)	10.701 (DOWN)
	4.500	12.75	3.958	-6.147 (UP)	13.515 (DOWN)

Example: Consider an 8-5/8" X 3-1/2" HD Packer set on 3.500" (10.20 lbs/ft) tubing with a differential pressure of 3,000 psi in the annulus around the tubing above the packer. What is the force acting on the seal area of the mandrel?

To calculate the force (lbs) acting on the seal area of the mandrel, refer to the Pressure Affected Area Guide for an 8-5/8" X 3-1/2" HD Packer run on 3.500" (10.20 lbs/ft) tubing. In this example, the differential pressure from above the packer acts on the seal area of the packer mandrel across a pressure affected area of 0.136 in². Multiplying the differential pressure (3,000 psi) by the pressure affected area (0.136 in²) results in a force of 408 lbs. The piston effect on the packer mandrel is a downward force of 480 lbs.

H) ELASTOMER TRIM TEMPERATURE GUIDE

NITRILE (STD)			
TEMPERATURE RANGE (F°)	DUROMETER		
	END	MIDDLE	END
40° - 125°	80	70	80
125° - 250°	90	70	90
150° - 250°	90	80	90
250° +	Contact D&L Sales		

RUBBER TYPE	TEMPERATURE RANGE (F°)
NITRILE	40° - 250°F
HSN (HNBR)	70° - 300°F
VITON	100° - 350°F



HD RETRIEVABLE PACKER RIGHT-HAND MANUAL 8-5/8" X 3-1/2", NC 50 TOOL JOINT

Manual No:
DL-613-8625-1662

Revision: **A**

Revision Date:
03/28/2023

Authored by: J.Anderson

Approved by: E.Visaez

I) RECOMMENDED TOOLS

I-1) HAND TOOLS

- VISE
- GLOVES
- ALLEN WRENCHES
- TAPE MEASURE
- O-RING PICK
- BAR
 - 1/2-INCH
 - 3/4-INCH
- PAINT BRUSH, 2-INCH
- PIPE WRENCH, 3-FT (2 EA)
- "CHEATER" PIPE, 4-FT LONG
- ADJUSTABLE WRENCH, 12-INCH
- CORDLESS DRILL, 18V
- SNAP RING SPREADER PLIERS
- ALIGNING PUNCH
- SCREWDRIVER SET, FLAT-TIPPED
- SOCKET SETS
 - 3/8-INCH DRIVE
 - 1/2-INCH DRIVE
- HAMMERS
 - SLEDGE
 - BALL PEEN
 - DEAD BLOW
- JACK STANDS

I-2) SPECIAL TOOLS

ITEM	QTY	DESCRIPTION	PART NUMBER
T1	1	DRAG BLOCK ASSEMBLY TOOL	AT095110
T2	1	BUTTON REMOVAL TOOL	AT-BRT000
T3	1 GAL	KOPR-KOTE® ANTI-SEIZE LUBRICANT	DL-KOPR-KOTE-1G

J) DISASSEMBLY

NOTE₂: Ensure vise is capable of handling weight of tool.

NOTE₃: Support tool during disassembly and assembly with jack stands as necessary.

J-1) Clamp top sub (1) in vise.

J-1.1) From lower end of tool, unscrew and remove set screws (34) from bottom sub (48).

J-1.2) Unscrew and remove bottom sub (48) from J-pin sub (23).

J-1.2.1) Remove o-ring (40) from bottom sub (48).

J-1.3) Unscrew and remove set screws (34) from J-pin sub (23). Move J-body (20) as needed to access set screws (34).

J-1.4) Unscrew and remove J-pin sub (23) from inner mandrel (2).

NOTE₄: Drag block body assembly must be free to rotate.

J-1.4.1) Remove o-ring (40) from J-pin sub (23).

J-1.5) Compress drag blocks (22) with drag block assembly tool (T1).

J-1.6) Unscrew and remove set screws (36) from J-body (20).

J-1.7) Unscrew and remove J-body (20) from drag block body (18) (**NOTE₅:** Left-hand threads).

J-1.8) Remove drag block retainer (21) from drag block body (18).

J-1.9) Release drag blocks (22). Remove drag blocks (22) and drag block springs (3) from drag block body (18).

J-1.10) Unscrew and remove rubber mandrel cap (19) from rubber mandrel (11).

NOTE₆: For added leverage, insert a rod through rubber retainer (15) and rubber mandrel (11) as needed.

J-1.11) Remove drag block body assembly and disassemble:

J-1.11.1) Unscrew and remove cap screws (38) from drag block body (18).

J-1.11.2) Wedge lower slips (17) outward (if needed). Remove lower slip support (32) from drag block body (18).

J-1.11.3) Remove wedges (if needed). Remove lower slips (17) and lower slip springs (25) from drag block body (18).



HD RETRIEVABLE PACKER RIGHT-HAND MANUAL 8-5/8" X 3-1/2", NC 50 TOOL JOINT

Manual No:
DL-613-8625-1662

Revision: A

Revision Date:
03/28/2023

Authored by: J.Anderson

Approved by: E.Visaez

J) DISASSEMBLY (cont'd)

- J-1.12) Unscrew and remove lower cone (16) from rubber retainer (15).
- J-1.13) Unscrew rubber mandrel (11) from valve body (28).
- J-1.14) Remove rubber mandrel assembly and disassemble:
 - J-1.14.1) Remove elements (13, 14), rubber spacers (12) and rubber retainer (15) from rubber mandrel (11).
- J-1.15) Unscrew and remove gage ring (28) from valve body (28).
- J-1.16) Unscrew and remove valve body (28) from central body (10).
 - J-1.16.1) Remove o-ring (42) from valve body (28).
- J-1.17) Unscrew and remove central body (10) from hold down body (6).
- J-2) Unclamp and remove top sub (1) from vise. Clamp lower end of inner mandrel (2) in vise.
 - CAUTION:** Do NOT wrench or clamp on seal surface.
 - J-2.1) Unscrew and remove set screws (35) from top sub (1).
 - J-2.2) Unscrew and remove top sub (1) from inner mandrel (2).
 - J-2.2.1) Remove o-ring (41) from top sub (1).
 - J-2.3) Unscrew and remove hold down extension (33) from hold down body (6).
 - J-2.3.1) Remove o-rings (45) from hold down extension (33).
 - J-2.4) Unscrew and remove hold down cap (4) from hold down body (6).
 - J-2.5) Move strap retainer (31) downwards temporarily out of way.
 - J-2.6) Unscrew and remove flat head cap screws (37) from hold down body (6).
 - J-2.7) Remove hold down straps (7) from hold down body (6).
 - J-2.8) Remove hold down button springs (26) from hold down buttons (30).
 - J-2.9) Remove hold down buttons (30) from hold down body (6) with button removal tool (T2).
 - J-2.9.1) Remove o-rings (39) from hold down buttons (30).
 - J-2.10) Remove hold down body (6) from inner mandrel (2).
 - J-2.10.1) Remove o-rings (43, 47) from hold down body (6).
 - J-2.11) Remove strap retainer (31) from inner mandrel (2).
 - J-2.12) Unscrew and remove compensating mandrel (8) from seal receptacle (5).
 - J-2.13) Remove compensating piston (9) from compensating mandrel (8).
 - J-2.13.1) Remove o-rings (46, 47) from compensating piston (9).
- J-3) Unclamp and remove inner mandrel (2) from vise.
 - J-3.1) Remove seal receptacle (5) from inner mandrel (2).
 - J-3.1.1) Unscrew and remove seal retainer (27) from seal receptacle (5).
 - J-3.1.2) Remove o-rings (43, 44) and quad seal (24) from seal receptacle (5).



HD RETRIEVABLE PACKER RIGHT-HAND MANUAL 8-5/8" X 3-1/2", NC 50 TOOL JOINT

Manual No:
DL-613-8625-1662

Revision: A

Revision Date:
03/28/2023

Authored by: J.Anderson

Approved by: E.Visaez

K) ASSEMBLY

NOTE7: Clean and inspect all parts. Replace all worn and damaged parts. Install parts in proper order, orientation and tighten/torque all connections properly.

CAUTION7: To ensure tool operates properly, install o-rings in o-ring grooves **NOT** thread reliefs (Fig. 2).

NOTE8: Apply KOPR-KOTE® anti-seize lubricant (T3) on STUB ACME and drill pipe connections when making up connections.

NOTE9: Ensure vise is capable of handling weight of tool.

NOTE10: Support tool during disassembly and assembly with jack stands as necessary.

K-1) Assemble seal receptacle assembly and install:

K-1.1) Install o-rings (43, 44) into o-ring grooves in seal receptacle (5).

K-1.2) Install seal (24) in place on seal receptacle (5).

K-1.3) Screw seal retainer (27) onto seal receptacle (5).

CAUTION8: Do not rip or tear o-rings or seal during installation.

K-1.4) Install seal receptacle (5) and assembly onto inner mandrel (2).

K-2) Clamp lower part of inner mandrel (2) in vise.

CAUTION6: Do **NOT** wrench or clamp on seal surface.

K-2.1) Assemble compensating mandrel assembly and install:

K-2.1.1) Install o-rings (46, 47) into o-ring grooves in compensating piston (9).

K-2.1.2) Install compensating piston (9) onto compensating mandrel (8).

NOTE11: Compensating piston **MUST** be installed in correct direction (Fig. 3).

CAUTION9: Do not rip or tear o-ring during installation.

K-2.1.3) Screw compensating mandrel (8) into seal receptacle (5).

K-2.2) Install strap retainer (31) onto inner mandrel (2). Move strap retainer (31) downwards temporarily out of way.

K-2.3) Install o-rings (43, 47) into o-ring grooves in hold down body (6).

K-2.4) Install o-rings (45) into o-ring grooves in hold down extension (33).

K-2.5) Screw hold down extension (33) into hold down body (6).

K-2.6) Install hold down body (6) onto inner mandrel (2).

K-2.7) Assemble hold down buttons and install:

K-2.7.1) Install o-rings (39) into o-ring grooves in hold down buttons (30).

K-2.7.2) Install hold down buttons (30) into hold down body (6) (Fig. 4).

CAUTION9: Do not rip or tear o-rings during installation.

K-2.7.3) Align slot in hold down buttons (30) with slot in hold down body (6). Install hold down button springs (26) into hold down buttons (30).

NOTE12: Install two (2ea) hold down button springs (26) per hold down button (Fig. 5).

K-2.7.4) Set hold down straps (7) in slots in hold down buttons (30) and hold down body (6).

K-2.7.5) Screw flat head cap screws (37) into hold down body (6) securing hold down straps (7).

K-2.8) Screw hold down cap (4) onto hold down body (6) capturing ends of hold down straps (7).

K-2.9) Install strap retainer (31) onto hold down body (6) capturing ends of hold down straps (7).

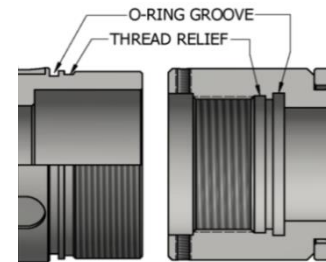

Fig. 2

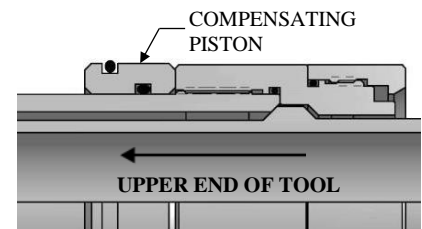

Fig. 3

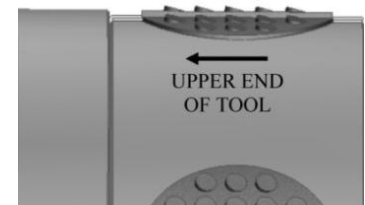

Fig. 4

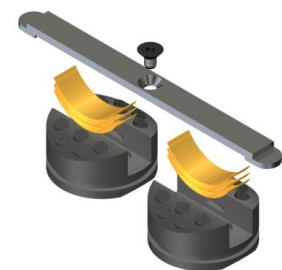

Fig. 5



HD RETRIEVABLE PACKER RIGHT-HAND MANUAL 8-5/8" X 3-1/2", NC 50 TOOL JOINT

Manual No:
DL-613-8625-1662

Revision: A

Revision Date:
03/28/2023

Authored by: J.Anderson

Approved by: E.Visaez

K) ASSEMBLY (cont'd)

K-2.10) Install o-ring (41) into o-ring groove in top sub (1).

K-2.11) Screw top sub (1) onto inner mandrel (2).

CAUTION: Do not rip or tear o-rings during installation.

K-2.12) Screw set screws (35) into top sub (1).

K-3) Unclamp and remove inner mandrel (2) from vise. Clamp top sub (1) in vise.

K-3.1) Screw central body (10) onto hold down body (6).

CAUTION: Do not rip or tear o-rings during installation.

K-3.2) Install o-ring (42) into o-ring groove in valve body (28).

K-3.3) Screw valve body (28) into central body (10).

K-3.4) Screw gage ring (29) onto valve body (28).

K-3.5) Assemble rubber mandrel assembly and install:

K-3.5.1) Install rubber retainer (15), rubber spacers (12), and elements (13, 14) onto rubber mandrel (11).

K-3.5.2) Screw rubber mandrel (11) into valve body (28).

CAUTION: Do not rip or tear o-ring during installation.

K-3.6) Screw lower cone (16) into rubber retainer (15).

K-3.7) Assemble drag block body assembly and install:

K-3.7.1) Install lower slips (17) and lower slip springs (25) into drag block body (18). Wedge lower slips (17) outward.

NOTE₁₃: Install two (2ea) springs per slip (Fig. 6).

K-3.7.2) Install lower slip support (32) into drag block body (18). Align holes in lower slip support (32) with threaded holes in drag block body (18).

K-3.7.3) Screw cap screws (38) into drag block body (18). Remove wedges.

K-3.7.4) Install drag block body (18) and assembly onto rubber mandrel (11).

K-3.8) Screw rubber mandrel cap (19) onto rubber mandrel (11).

K-3.9) Install drag blocks (22) and drag block springs (3) into drag block body (18). Compress drag blocks (22) with drag block assembly tool (T1).

NOTE₁₄: Install six (6ea) drag block springs per drag block (Fig. 7).

K-3.10) Install drag block retainer (21) capturing ends of drag blocks (22).

K-3.11) Screw J-body (20) onto drag block body (18) (**NOTE:** Left-hand threads).

K-3.12) Screw set screws (36) into J-body (20). Release drag blocks (22).

K-3.13) Install o-ring (40) into o-ring groove in J-pin sub (23).

K-3.14) Screw J-pin sub (23) onto inner mandrel (2).

NOTE₄: Drag block body assembly must be free to rotate.

CAUTION: Do not rip or tear o-ring during installation.

K-3.15) Screw set screws (34) into J-pin sub (23). Move J-body (20) as needed to access threaded holes in J-pin sub (23).

K-3.16) Install o-ring (40) in o-ring groove in bottom sub (48).

K-3.17) Screw bottom sub (48) onto J-pin sub (23).

CAUTION: Do not rip or tear o-ring during installation.

K-3.18) Screw set screws (34) into bottom sub (48).

K-4) Unclamp top sub (1) from vise and remove assembled tool.

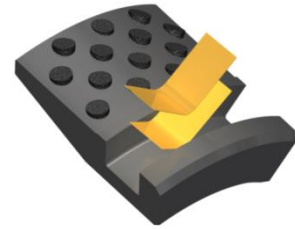

Fig. 6



Fig. 7



HD RETRIEVABLE PACKER RIGHT-HAND MANUAL

8-5/8" X 3-1/2", NC 50 TOOL JOINT

Manual No:
DL-613-8625-1662

Revision: **A**

Revision Date:
03/28/2023

Authored by: *J.Anderson*

Approved by: *E.Visaez*

L) PARTS LIST

ITEM	QTY	DESCRIPTION	MATERIAL	P/N 61387RM-XBEE
1	1	TOP SUB	DLMS110	61387615-YBEE
2	1	INNER MANDREL	DLMS110	61387215
3	36	DRAG BLOCK SPRING	-	9101900
4	1	HOLD DOWN CAP	DLMS110	61387370
5	1	SEAL RECEPTACLE	DLMS110	61387730
6	1	HOLD DOWN BODY	DLMS110	61387320
7	3	HOLD DOWN STRAP	DLMSFB4	61370360
8	1	COMPENSATING MANDREL	DLMS110	61387240
9	1	COMPENSATING PISTON	DLMS110	61387715
10	1	CENTRAL BODY	DLMS110	61387385
11	1	RUBBER MANDREL	DLMS110	61387220
12	2	RUBBER SPACER	DLMS35	60285840
13	1	ELEMENT	80 DURO NITRILE	60285512
14	2	ELEMENT	90 DURO NITRILE	60285513
15	1	RUBBER RETAINER	DLMS35	60285850
16	1	LOWER CONE	DLMS110	60387420HT
17	4	CARBIDE LOWER SLIP	DLMS110	60085135C
18	1	DRAG BLOCK BODY	DLMS35	60087335
19	1	RUBBER MANDREL CAP	DLMS35	60073230
20	1	J-BODY	DLMS110	61387342
21	1	DRAG BLOCK RETAINER	DLMS35	60387910
22	6	700 CARBIDE DRAG BLOCK	DLMSDB4	9070900C
23	1	J-PIN SUB	DLMS110	61387630-YAB
24	1	SEAL	90 DURO NITRILE	61387520
25	8	LOWER SLIP SPRING	-	7170901
26	12	HOLD DOWN BUTTON SPRING	-	61370975
27	1	SEAL RETAINER	DLMS110	61387530
28	1	VALVE BODY	DLMS110	61387350
29	1	UPPER GAGE RING	DLMS35	60287830
30	6	CARBIDE HOLD DOWN BUTTON	DLMSSP	61387140C
31	1	STRAP RETAINER	DLMS110	61387650
32	1	LOWER SLIP SUPPORT	DLMS35	60387912
33	1	HOLD DOWN EXTENSION	DLMS110	61387310
34	6	1/4-20 UNC X 7/16 SOCKET SET SCREW	STEEL	SSS025C043
35	3	3/8-16 UNC X 1/2 SOCKET SET SCREW	STEEL	SSS037C050
36	2	3/8-16 UNC X 3/8 SOCKET SET SCREW	STEEL	SSS037C037



HD RETRIEVABLE PACKER RIGHT-HAND MANUAL

8-5/8" X 3-1/2", NC 50 TOOL JOINT

Manual No:
DL-613-8625-1662

Revision: **A**

Revision Date:
03/28/2023

Authored by: *J.Anderson*

Approved by: *E.Visaez*

L) PARTS LIST (cont'd)

ITEM	QTY	DESCRIPTION	MATERIAL	P/N 61387RM-XBEE
37	3	5/16-18 UNC X 1/2 FLAT HEAD SOCKET CAP SCREW	STEEL	FHSC031C050
38	2	5/8-11 UNC X 1 SOCKET CAP SCREW	STEEL	SCS062C100
39	6	230 O-RING	90 DURO NITRILE	90230
40	2	237 O-RING	90 DURO NITRILE	90237
41	1	239 O-RING	90 DURO NITRILE	90239
42	1	243 O-RING	90 DURO NITRILE	90243
43	2	245 O-RING	90 DURO NITRILE	90245
44	1	248 O-RING	90 DURO NITRILE	90248
45	2	343 O-RING	90 DURO NITRILE	90343
46	1	348 O-RING	90 DURO NITRILE	90348
47	2	356 O-RING	90 DURO NITRILE	90356
48	1	BOTTOM SUB	DLMS110	61387635-YBEE

REDRESS KIT (RDK)	61387050-XBEE
ASSEMBLED WEIGHT	622 LBS

L-1) ELASTOMER TRIM OPTIONS

NOTE₁₅: For temperature range, refer to Elastomer Trim Temperature Guide.

L-1.1) HSN

ITEM	QTY	DESCRIPTION	MATERIAL	P/N 61387RMH-XBEE
13	1	ELEMENT	80 DURO HSN	60285512H
14	2	ELEMENT	90 DURO HSN	60285513H
24	1	SEAL	90 DURO HSN	61387520H
39	6	230 O-RING	90 DURO HSN	90230H
40	2	237 O-RING	90 DURO HSN	90237H
41	1	239 O-RING	90 DURO HSN	90239H
42	1	243 O-RING	90 DURO HSN	90243H
43	2	245 O-RING	90 DURO HSN	90245H
44	1	248 O-RING	90 DURO HSN	90248H
45	2	343 O-RING	90 DURO HSN	90343H
46	1	348 O-RING	90 DURO HSN	90348H
47	2	356 O-RING	90 DURO HSN	90356H

REDRESS KIT (RDK)	61387050H-XBEE
-------------------	----------------



HD RETRIEVABLE PACKER RIGHT-HAND MANUAL 8-5/8" X 3-1/2", NC 50 TOOL JOINT

Manual No:
DL-613-8625-1662

Revision: **A**

Revision Date:
03/28/2023

Authored by: *J.Anderson*

Approved by: *E.Visaez*

L) PARTS LIST (cont'd)

L-1.2) VITON

ITEM	QTY	DESCRIPTION	MATERIAL	P/N 61387RMV-XBEE
13	1	ELEMENT	80 DURO VITON	60285512V
14	2	ELEMENT	90 DURO VITON	60285513V
24	1	SEAL	90 DURO VITON	61387520V
39	6	230 O-RING	90 DURO VITON	90230V
40	2	237 O-RING	90 DURO VITON	90237V
41	1	239 O-RING	90 DURO VITON	90239V
42	1	243 O-RING	90 DURO VITON	90243V
43	2	245 O-RING	90 DURO VITON	90245V
44	1	248 O-RING	90 DURO VITON	90248V
45	2	343 O-RING	90 DURO VITON	90343V
46	1	348 O-RING	90 DURO VITON	90348V
47	2	356 O-RING	90 DURO VITON	90356V
REDRESS KIT (RDK)				61387050V-XBEE



HD RETRIEVABLE PACKER RIGHT-HAND MANUAL 8-5/8" X 3-1/2", NC 50 TOOL JOINT

Manual No:
DL-613-8625-1662

Revision: A

Revision Date:
03/28/2023

Authored by: J.Anderson

Approved by: E.Visaez

M) TECHNICAL ILLUSTRATION

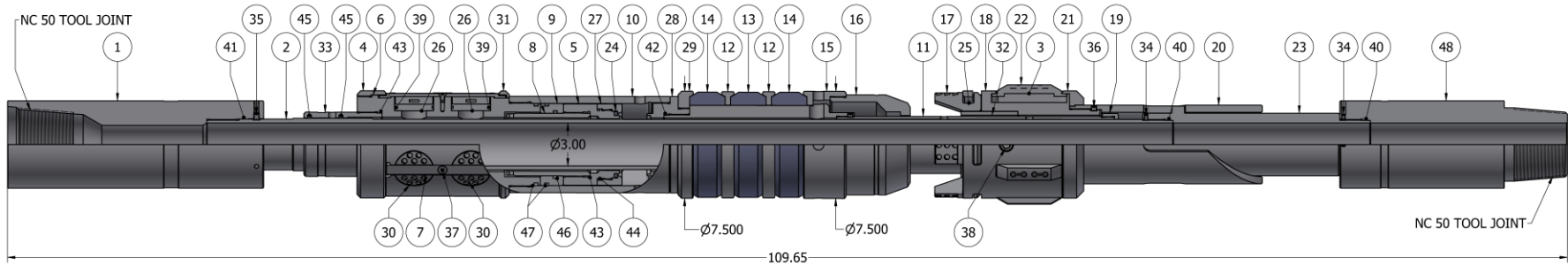

	<p align="center">HD RETRIEVABLE PACKER RIGHT-HAND MANUAL</p> <p align="center">8-5/8" X 3-1/2", NC 50 TOOL JOINT</p>	Manual No: DL-613-8625-1662
		Revision: A
		Revision Date: 03/28/2023
<i>Authored by: J.Anderson</i>		<i>Approved by: E.Visaez</i>

N) REVISION HISTORY

DATE	REVISION	DESCRIPTION OF CHANGES	REVISED BY	APPROVED BY
03/28/2023	A	Created manual	-	-