



PUMP-OUT PLUG

2-3/8", SOLID PLUG, PIN BOTTOM

Manual No:
DL-597-2375-1712

Revision: **B**

Revision Date:
11/01/2023

Authored by: J.Anderson

Approved by: E.Visaez

A) DESCRIPTION

The Pump-Out Plug provides a means to temporarily plug the tubing string. The Pump-Out Plug can be set up to either be run in as a solid plug or with a ball seat that allows the string to fill on the trip in. The pressure required to shear the pins and pump the plug out of the pump out plug housing is adjustable.

When run as a solid plug, pressure from below does not load the shear pins. When an expendable ball seat is used the string is pressure balanced.

NOTE₁: Any hydrostatic pressure below the plug must be overcome before the shear pins are loaded and must be considered when calculating pump out pressure.

B) SPECIFICATION GUIDE

TUBING SIZE (INCHES)	GAGE OD (INCHES)	NOMINAL ID (INCHES)	THREAD CONNECTION BOX UP / PIN DOWN	PART NUMBER
2.375	3.25	1.88	2-3/8 EUE	59720E-3 59720EH-3 ¹ 59720EV-3 ²

Elastomer Trim Options: ¹HSN, ²Viton

C) PRE-INSTALLATION INSPECTION PROCEDURES

CAUTION: D&L ships tool connections made-up **HAND TIGHT**—labeled with hand-tight tape on the tool (Fig. 1)—unless stated otherwise. Tighten/torque all connections properly before operating tool.



Fig. 1

GENERAL THREAD CONNECTION TORQUE RECOMMENDATIONS			
STUB ACME / ACME THREADS	INTERNAL TAPERED TUBING THREADS		PREMIUM THREADS
	UP TO 2-3/8"	GREATER THAN 2-3/8"	
600 – 800 FT-LBS	600 – 800 FT-LBS	800 – 1,200 FT-LBS	Consult thread manufacturer's recommendations.

GENERAL SCREW TORQUE RECOMMENDATIONS									
SCREW SIZE (INCHES)	#6	#8	#10	1/4	5/16	3/8	7/16	1/2	5/8 and larger
TORQUE RANGE (INCH-POUNDS)	5 – 8	10 – 15	18 – 25	25 – 40	50 – 80	90 – 135	160 – 210	250 – 330	450 - 650

Before first use, D&L recommends disassembly and inspection of the tool unless stated otherwise. Ensure parts have not been damaged during shipping. Replace damaged parts with D&L replacement parts. Contact D&L sales for replacement part information.

Re-assemble the tool after inspection. Install parts in the correct order and orientation. Properly tighten connections.

D) RUNNING PROCEDURES

Make up pump-out plug on workstring and run downhole. Apply pressure to shear screws (271 psi/screw) and expel solid plug. The number of shear screws is adjustable for desired shear out pressure.

D & L OIL TOOLS
P.O. BOX 52220 TULSA, OK 74152
PHONE: (800) 441-3504 www.dloiltools.com



PUMP-OUT PLUG

2-3/8", SOLID PLUG, PIN BOTTOM

Manual No:
DL-597-2375-1712

Revision: **B**

Revision Date:
11/01/2023

Authored by: J.Anderson

Approved by: E.Visaez

E) STORAGE RECOMMENDATIONS

When preparing the tool for storage, follow the Pre-Installation Inspection Procedures. Re-assemble the tool with connections hand-tight only and in running position if applicable.

Store the tool, if possible, in an enclosed, temperature and humidity controlled environment. Avoid excessively high temperatures over long periods of time. Shield elastomeric parts from ultraviolet light sources. Keep tool dry and protected from condensation. Do not store in contact with or near volatile or corrosive chemicals. Do not store near ozone generating equipment or operations such as welding.

F) ELASTOMER TRIM TEMPERATURE GUIDE

RUBBER TYPE	TEMPERATURE RANGE
NITRILE	40° - 250°F
HSN (HNBR)	70° - 300°F
VITON	100° - 350°F

G) RECOMMENDED HAND TOOLS

- VISE
- GLOVES
- ALLEN WRENCHES
- TAPE MEASURE
- O-RING PICK
- BAR
 - 1/2-INCH
 - 3/4-INCH
- PAINT BRUSH, 2-INCH
- PIPE WRENCH, 3-FT (2 EA)
- "CHEATER" PIPE, 4-FT LONG
- ADJUSTABLE WRENCH, 12-INCH
- STRAP WRENCH
- CORDLESS DRILL, 18V
- SNAP RING SPREADER PLIERS
- ALIGNING PUNCH
- SCREWDRIVER SET, FLAT-TIPPED
- SOCKET SETS
 - 3/8-INCH DRIVE
 - 1/2-INCH DRIVE
- HAMMERS
 - SLEDGE
 - BALL PEEN
 - DEAD BLOW

H) DISASSEMBLY

H-1) Clamp top sub (1) in vise.

H-1.1) Unscrew and remove set screws (5) from bottom sub (2).

H-1.2) Unscrew and remove bottom sub (2) from top sub (1).

H-1.3) Unscrew and remove shear screws (4) from top sub (1),

H-1.4) Remove plug insert (3) from top sub (1).

H-1.4.1) Remove o-ring (6) from plug insert (3).

H-2) Unclamp top sub (1) and remove from vise.

H-2.1) Remove o-ring (7) from top sub (1).

I) ASSEMBLY

NOTE₂: Clean and inspect all parts. Replace all worn and damaged parts. Install parts in proper order and orientation.

I-1) Install o-ring (7) in o-ring groove in top sub (1).

I-2) Clamp top sub (1) in vise.

I-2.1) Install o-ring (6) in groove in plug insert (3).

I-2.2) Install plug insert (3) into top sub (1). Align groove in plug insert (3) with threaded holes in top sub (1).

CAUTION₂: Do not rip or tear o-ring during installation.

I-2.3) Screw shear screws (4) into top sub (1). Tighten until shear screws (4) contact plug insert (3). Back shear screws (4) out 1/4 turn.



PUMP-OUT PLUG

2-3/8", SOLID PLUG, PIN BOTTOM

Manual No:
DL-597-2375-1712

Revision: **B**

Revision Date:
11/01/2023

Authored by: J.Anderson

Approved by: E.Visaez

I) ASSEMBLY (cont'd)

I-2.4) Screw bottom sub (2) onto top sub (1).

CAUTION: Do not rip or tear o-ring during installation.

I-2.5) Screw set screws (5) into bottom sub (2).

I-3) Unclamp top sub (1) and remove assembled tool from vise.

J) PARTS LIST

ITEM	QTY	DESCRIPTION	MATERIAL	P/N 59720E-3
1	1	TOP SUB	DLMS60	59720400
2	1	BOTTOM SUB	DLMS60	59720300
3	1	PLUG INSERT	DLM6061T6	59720255
4	10	#10-32 UNF X 3/8 SLOTTED SHEAR SCREW (750#)	DLM360BRS	BSSSLT1032F037
5	3	5/16-18 UNC X 5/16 SOCKET SET SCREW	STEEL	SSS031C031
6	1	223 O-RING	90 DURO NITRILE	90223
7	1	230 O-RING	90 DURO NITRILE	90230

ASSEMBLED WEIGHT	12 LBS
------------------	--------

J-1) ELASTOMER TRIM OPTIONS

NOTE₃: For temperature range, refer to Elastomer Trim Temperature Guide.

J-1.1) HSN

ITEM	QTY	DESCRIPTION	MATERIAL	P/N 59720EH-3
6	1	223 O-RING	90 DURO HSN	90223H
7	1	230 O-RING	90 DURO HSN	90230H

J-1.2) VITON

ITEM	QTY	DESCRIPTION	MATERIAL	P/N 59720EV-3
6	1	223 O-RING	90 DURO VITON	90223V
7	1	230 O-RING	90 DURO VITON	90230V



PUMP-OUT PLUG

2-3/8", SOLID PLUG, PIN BOTTOM

Manual No:
DL-597-2375-1712

Revision: **B**

Revision Date:
11/01/2023

Authored by: J.Anderson

Approved by: E.Visaez

K) TECHNICAL ILLUSTRATION

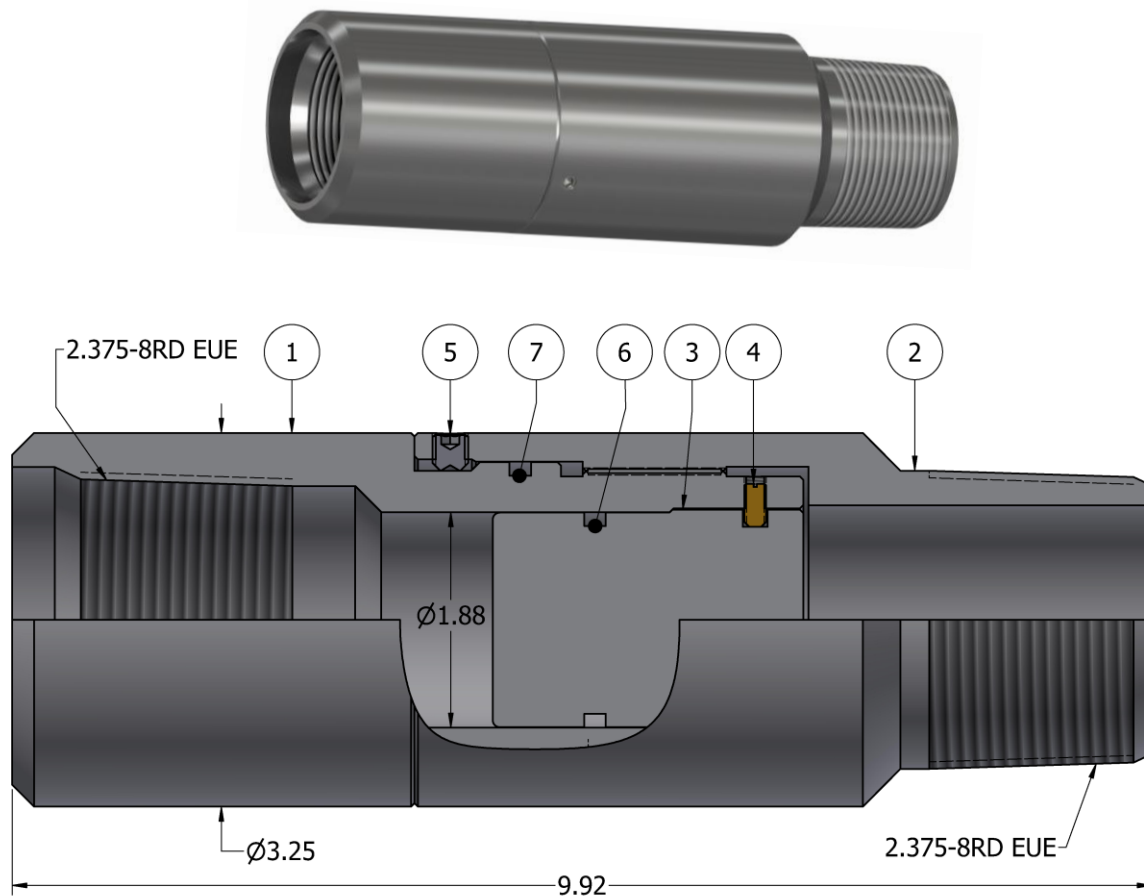

L) REVISION HISTORY

DATE	REVISION	DESCRIPTION OF CHANGES	REVISED BY	APPROVED BY
11/01/2023	B	Corrected shear screw quantity	J.Anderson	E.Visaez
10/31/2023	A	Created manual	-	-